

# Automation and control

## **Soft starters and variable speed drives**

Catalogue

# 2007/2008



# Soft starters for asynchronous motors

## Altistart U01 and TeSys U

1

1.2

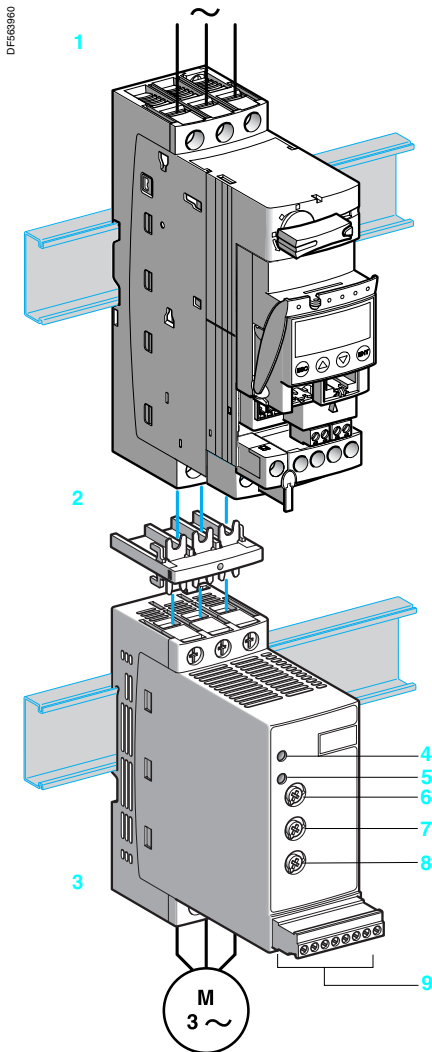

### Presentation

The Altistart U01 is a soft start/soft stop unit for asynchronous motors. It is designed primarily for combinations with **TeSys U** controller-starters.

When combined with a **TeSys U 1** controller by means of a connector **2**, the Altistart U01 **3** is a power option which provides the "Soft start/soft stop" function. The result is a unique, innovative motor starter.

Using the Altistart U01 starter enhances the starting performance of asynchronous motors by allowing them to start gradually, smoothly and in a controlled manner. It prevents mechanical shocks, which lead to wear and tear, and limits the amount of maintenance work and production downtime.

The Altistart U01 limits the starting torque and current peaks on starting, on machines which do not require a high starting torque.

The Altistart U01 is designed for the following simple applications:

- Conveyors
- Conveyor belts
- Pumps
- Fans
- Compressors
- Automatic doors and gates
- Small cranes
- Belt-driven machines, etc.

The Altistart U01 is compact and easy to install. It complies with standards IEC/EN 60947-4-2, carries UL, CSA, C-Tick, CCC and GOST certifications and **CE** marking.

#### ■ ATSU 01N2●●LT soft start/soft stop units

- Control two phases of the motor power supply to limit the starting current and for deceleration
  - Internal bypass relay
  - Motor power ratings ranging from 0.75 kW to 15 kW
  - Motor supply voltages ranging from 200 V to 480 V, 50/60 Hz.
- An external power supply is required for controlling the starter.

### Description

- Altistart U01 soft start/soft stop units are equipped with:
  - A potentiometer for setting the starting time **6**
  - A potentiometer for setting the deceleration time **8**
  - A potentiometer for adjusting the start voltage threshold according to the motor load **7**
  - 1 green LED **4** to indicate that the unit is switched on
  - 1 yellow LED **5** to indicate that the motor is powered at nominal voltage, if it is connected to the starter
  - A connector **9**:
    - 2 logic inputs for Run/Stop commands
    - 1 logic input for the BOOST function
    - 1 logic output to indicate the end of starting
    - 1 relay output to indicate the starter has a power supply fault or the motor has reached a standstill at the end of the deceleration stage

# Soft starters for asynchronous motors

## Altistart U01 and TeSys U

### Description of a TeSys U controller-starter

Please consult the “TeSys U starters - open version” catalogue.

### ATSU 01N2●●●LT soft start unit functions

#### ■ 2-wire control

The run and stop commands are controlled by a single logic input. State 1 of logic input LI2 controls starting and state 0 controls stopping.

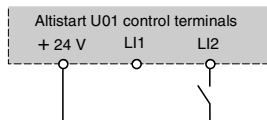

Wiring diagram for 2-wire control

#### ■ 3-wire control

The run and stop commands are controlled by 2 different logic inputs. Stopping is achieved when logic input LI1 opens (state 0). The pulse on input LI2 is stored until input LI1 opens.

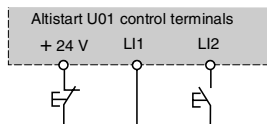

Wiring diagram for 3-wire control

#### ■ Starting time

Controlling the starting time means that the time of the voltage ramp applied to the motor can be adjusted to obtain a gradual starting time, dependent on the motor load.

#### ■ Voltage boost function via logic input

Activating the BOOST logic input enables the function for supplying a starting overtorque capable of overcoming any mechanical friction. When the input is at state 1, the function is active (input connected to the + 24 V) and the starter applies a fixed voltage to the motor for a limited time before starting.

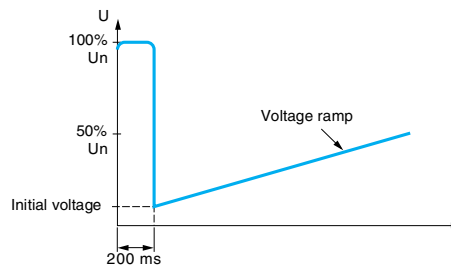

Application of a voltage boost equal to 100% of the nominal motor voltage

#### ■ End of starting

##### □ Application function for logic output LO1

ATSU 01N2●●●LT soft start/soft stop units are equipped with an open collector logic output LO, which indicates the end of starting when the motor has reached nominal speed.

# Soft starters for asynchronous motors

## Altistart U01 and TeSys U

1

1.2

### Environmental characteristics

<b>Type of starter</b>		<b>ATSU 01N2●●LT</b>	
<b>Conformity to standards</b>		Altistart U01 electronic starters have been developed to conform to the strictest international standards and the recommendations relating to electrical industrial control devices (IEC, EN), in particular standard IEC/EN 60947-4-2.	
<b>Electromagnetic compatibility EMC</b>		CISPR 11 level B, IEC 60947-4-2, level B	
	Conducted and radiated emissions	IEC 1000-3-2, IEC 1000-3-4	
	Harmonics	EN 50082-2, EN 50082-1	
	EMC immunity	IEC 61000-4-2 level 3	
	Electrostatic discharge	IEC 61000-4-3 level 3	
	Immunity to radiated radio-electrical interference	IEC 61000-4-4 level 4	
	Immunity to electrical transients	IEC 61000-4-5 level 3	
	Voltage/current impulse	IEC 61000-4-6 level 3	
	Conducted and radiated emissions	IEC 61000-4-11	
	Immunity to conducted interference caused by radio-electrical fields	IEC 61000-4-12 level 3	
	Damped oscillating waves	The starters carry CE marking in accordance with the European low voltage directives IEC/EN 60947-4-2.	
<b>CE marking</b>		The starters carry CE marking in accordance with the European low voltage directives IEC/EN 60947-4-2.	
<b>Product certifications</b>		UL, CSA, C-Tick, CCC and GOST	
<b>Degree of protection</b>		IP 20	
<b>Degree of pollution</b>		2 conforming to IEC/EN 60947-4-2	
<b>Vibration resistance</b>		1.5 mm peak to peak from 3 to 13 Hz, 1 gn from 13 to 150 Hz, conforming to IEC/EN 60068-2-6	
<b>Shock resistance</b>		15 gn for 11 ms conforming to IEC/EN 60068-2-27	
<b>Relative humidity</b>		5...95% without condensation or dripping water conforming to IEC 60068-2-3	
<b>Ambient temperature</b> around the unit	Storage	°C	- 25...+ 70 conforming to IEC/EN 60947-4-2
	Operation	°C	- 10...+ 40 without derating, up to 50°C with current derating of 2% per °C above 40°C
<b>Maximum operating altitude</b>		<b>m</b>	1000 without derating (above this, derate the current by 2.2% per additional 100 m)
<b>Operating position</b> Maximum permanent angle in relation to the normal vertical mounting position			

### Electrical characteristics

<b>Type of starter</b>		<b>ATSU 01N2●●LT</b>						
<b>Category of use</b>	Conforming to IEC 60947-4-2	Ac-53b						
<b>Rated operating voltage</b>	3-phase ~ voltage	200 - 15% to 480 + 10%						
<b>Frequency</b>		50 - 5% to 60 + 5%						
<b>Output voltage</b>		Maximum 3-phase voltage equal to line supply voltage						
<b>Control supply voltage</b>		24 V ~, 100 mA ± 10%						
<b>Rated operating current</b>	<b>A</b>	6...32						
<b>Adjustable starting time</b>	<b>s</b>	1...10						
<b>Adjustable deceleration time</b>	<b>s</b>	1...10						
<b>Starting torque</b>	<b>%</b>	30... 80% of DOL motor starting torque						
<b>Type of starter</b>	<b>ATSU</b>	<b>01N206LT</b>	<b>01N209LT</b>	<b>01N212LT</b>	<b>01N222LT</b>	<b>01N232LT</b>		
<b>Control power supply consumption</b>		24 V ~, 65 mA				24 V ~, 100 mA		
<b>Power dissipated</b>	At full load at end of starting	<b>W</b>	1.5	1.5	1.5	2.5	2.5	
	In transient state at 5 times the rated operating current	<b>W</b>	61.5	91.5	121.5	222.5	322.5	
<b>Type of starter</b>		<b>ATSU 01N206LT to ATSU 01N222LT</b>			<b>ATSU 01N232LT</b>			
<b>Use</b>	Starting time	<b>s</b>	1	5	10	1	5	10
	Maximum number of cycles per hour		100	20	10	50	10	5

# Soft starters for asynchronous motors

## Altistart U01 and TeSys U

### Electrical characteristics (continued)

<b>Logic input power supply</b> (electrically isolated between power and control) <b>+ 24 V, COM</b>		24 V ± 10% Isolated Max. current 100 mA
<b>Logic inputs</b> <b>LI1, LI2, BOOST</b> Stop, run and boost on start-up functions		Logic inputs with impedance 27 kΩ; 24 V power supply (U max 40 V) Max. current 8 mA State 0 if U < 5 V and I < 0.2 mA State 1 if U > 13 V and I > 0.5 mA
<b>Logic output LO1</b> End of starting signal		Open collector logic output: External 24 V power supply (minimum 6 V, maximum 30 V) Max. current 200 mA
<b>Relay output</b> <b>R1A R1C</b>		Normally open (N/O) contact Minimum switching capacity: 10 mA for 6 V ~ Maximum switching capacity on inductive load (cos φ = 0.5 and L/R = 20 ms): 2 A for 250 V ~ or 30 V ~ (AC-15) Maximum operating voltage 440 V
<b>LED signalling</b>	Green LED	Starter powered up
	Yellow LED	Nominal voltage reached

### Connections (maximum connection capacity and tightening torque)

<b>Power circuit</b>		Connection to Ø 4 mm screw clamps	
<b>Flexible wire without cable end</b>	1 conductor	mm <sup>2</sup>	1.5...10 8 AWG
	2 conductors	mm <sup>2</sup>	1.5...6 10 AWG
<b>Flexible wire with cable end</b>	1 conductor	mm <sup>2</sup>	1...6 10 AWG
	2 conductors	mm <sup>2</sup>	1...6 10 AWG
<b>Rigid wire</b>	1 conductor	mm <sup>2</sup>	1...10 8 AWG
	2 conductors	mm <sup>2</sup>	1...6 10 AWG
<b>Tightening torque</b>		<b>N.m</b>	1.9...2.5
<b>Control circuit</b>		Screw connector	
<b>Flexible wire without cable end</b>	1 conductor	mm <sup>2</sup>	0.5...2.5 14 AWG
	2 conductors	mm <sup>2</sup>	0.5...1.5 16 AWG
<b>Flexible wire with cable end</b>	1 conductor	mm <sup>2</sup>	0.5...1.5 16 AWG
	2 conductors	mm <sup>2</sup>	0.5...1.5 16 AWG
<b>Rigid wire</b>	1 conductor	mm <sup>2</sup>	0.5...2.5 14 AWG
	2 conductors	mm <sup>2</sup>	0.5...1 17 AWG
<b>Tightening torque</b>		<b>N.m</b>	0.5

### Torque characteristics (typical curves)

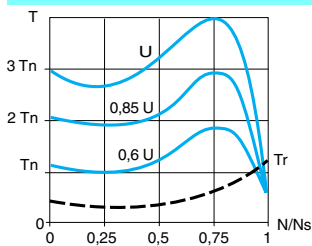

The diagram opposite shows the torque/speed characteristic of a cage motor in relation to the supply voltage. The torque varies in line with the square of the voltage at a fixed frequency. The gradual increase in the voltage prevents the instantaneous current peak on power-up.

# Soft starters for asynchronous motors

## Altistart U01 and TeSys U

1



ATSU 01N222LT

1.2

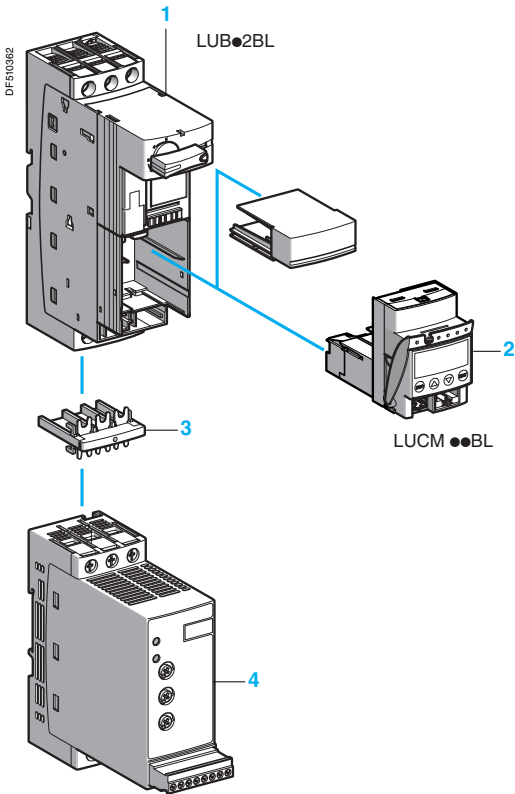

ATSU 01N2●●LT

### Soft start/soft stop units for 0.75 to 15 kW motors (can be combined with the TeSys U starter)

Motor				Starter		
Motor power (1)		400 V	460 V	Nominal current	Reference	Weight
230 V	230 V	kW	HP	A		kg
<b>3-phase supply voltage: 200...480 V 50/60 Hz</b>						
0.75	1	1.5	2	6	ATSU 01N206LT	0.340
1.1	1.5	2.2	3			
		3				
1.5	2	–	5	9	ATSU 01N209LT	0.340
–	–	4	–			
2.2	3	5.5	7.5	12	ATSU 01N212LT	0.340
3	–	–	–			
4	5	7.5	10	22	ATSU 01N222LT	0.490
5.5	7.5	11	15			
7.5	10	15	20	32	ATSU 01N232LT	0.490

### Accessories

Description	Used for starter	Reference	Weight kg
Power connector between ATSU 01N2●●LT and TeSys U	ATSU 01N2●●LT	VW3 G4104	0.020

### TeSys U starter and soft start unit combinations

Numerous possibilities for combinations and options are offered. Please consult the "TeSys U Starters-open version" specialist catalogue.

Motor power			Soft starter	TeSys U	
230 V	400 V	460 V		Power base	Control unit (2)
kW/HP	kW	HP			
0.75/1	1.5	2	ATSU 01N206LT	LUB 12	LUC● 05BL
1.1/1.5	2.2/3	3	ATSU 01N206LT	LUB 12	LUC● 12BL
1.5/2	–	–	ATSU 01N209LT	LUB 12	LUC● 12BL
–	4	5	ATSU 01N209LT	LUB 12	LUC● 12BL
2.2/3	–	–	ATSU 01N212LT	LUB 12	LUC● 12BL
3/–	5.5	7.5	ATSU 01N212LT	LUB 32	LUC● 18BL
4/5	7.5	10	ATSU 01N222LT	LUB 32	LUC● 18BL
5.5/7.5	11	15	ATSU 01N222LT	LUB 32	LUC● 32BL
7.5/10	15	20	ATSU 01N232LT	LUB 32	LUC● 32BL

Example of a starter-motor combination with:

- 1 non-reversing power base for DOL starting (LUB●2BL)
- 2 control unit (LUCM●●BL)
- 3 power connector (VW3 G4104)
- 4 Altistart U01 soft start/soft stop unit (ATSU 01N2●●LT)

(1) Standard motor power ratings, HP power ratings indicated according to standard UL 508.  
(2) Depending on the configuration of the chosen TeSys U starter, replace the ● with A for standard, B for expandable, and M for multifunction.

# Soft starters for asynchronous motors

Altistart U01 and TeSys U

TeSys U combination (non-reversing power base) and  
ATSU 01N206LT to ATSU 01N212LT

Mounting on  $\perp$  (35 mm) rail with VW3 G4104 connector

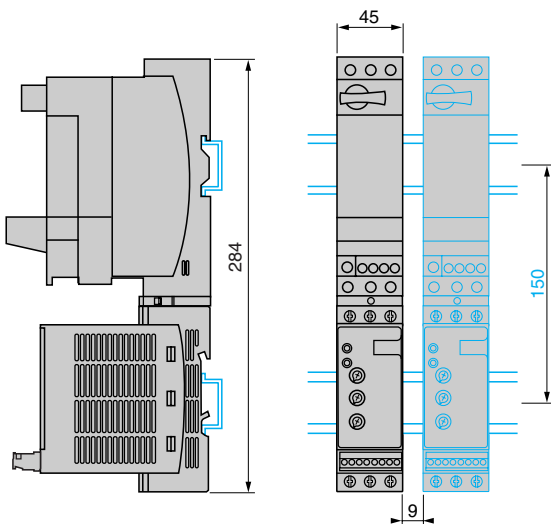

TeSys U combination (non-reversing or reversing power base)  
and ATSU 01N206LT to ATSU 01N212LT

Side by side mounting

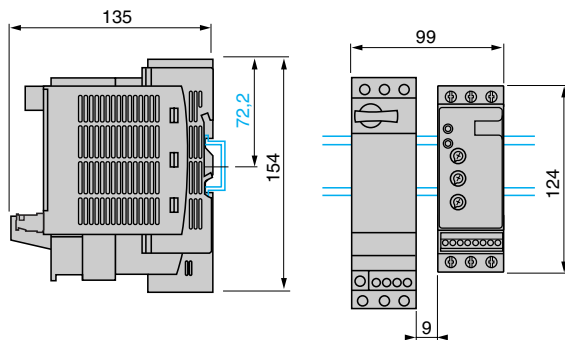

TeSys U combination (non-reversing power base) and  
ATSU 01N222LT to ATSU 01N232LT

Mounting on  $\perp$  (35 mm) rail with VW3 G4104 connector

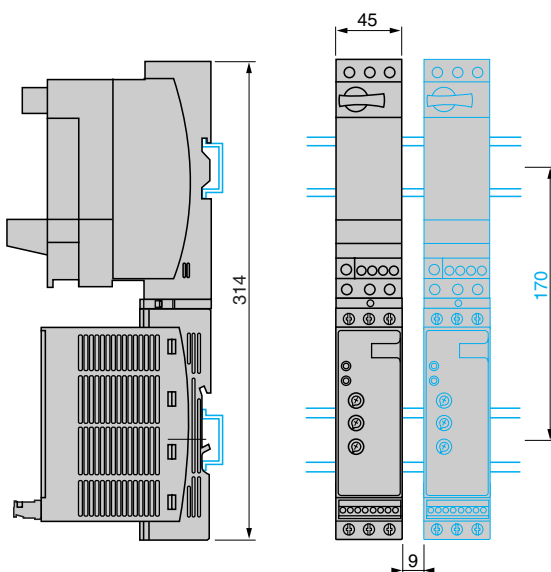

TeSys U combination (non-reversing or reversing power base)  
and ATSU 01N222LT to ATSU 01N232LT

Side by side mounting

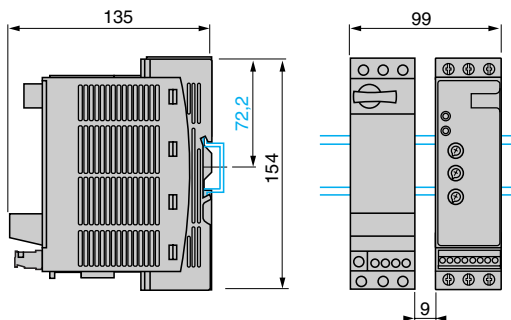

## VW3 G4104 connector

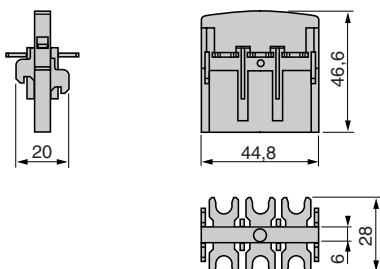

# Soft starters for asynchronous motors

Altistart U01 and TeSys U  
For 0.75 to 15 kW motors

1

1.2

## ATSU 01N2●●LT soft start/soft stop units

### Power wiring

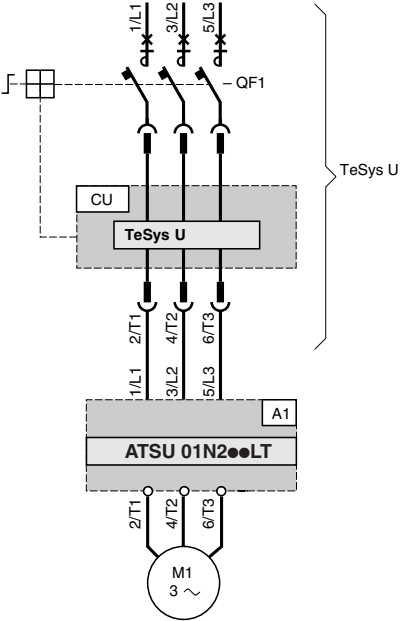

### Power wiring with reversing unit

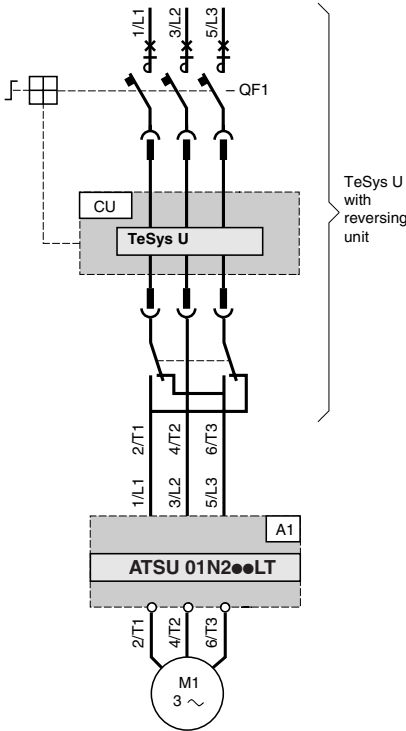

**Compatible components** (For full references, see pages 1/18 and 1/19 or refer to our catalogue: "Motor starter solutions - Control and protection components")

Code	Description
A1	Soft start/soft stop unit
QF1	TeSys U controller-starter
CU	TeSys U control unit



# Soft starters for asynchronous motors

Altistart U01 and TeSys U  
For 0.75 to 15 kW motors

## ATSU 01N2●●LT soft start/soft stop units (continued)

Automatic 3-wire control, with reversing unit

Without deceleration

With deceleration

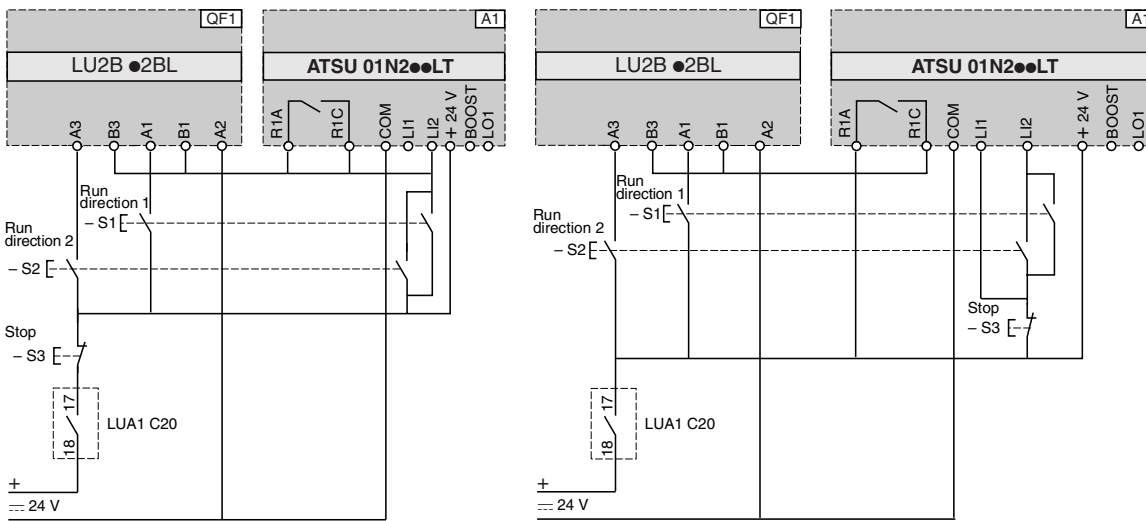

QF1: TeSys U controller-starter with reversing unit  
A1: Soft start/soft stop unit  
S1, S2, S3: XB4 B or XB5 B pushbuttons  
S3: minimum depression time 500 ms

QF1: TeSys U controller-starter with reversing unit  
A1: Soft start/soft stop unit  
S1, S2, S3: XB4 B or XB5 B pushbuttons

### Boost on starting and end of starting signal

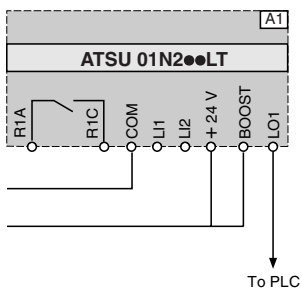

A1: Soft start/soft stop unit

# Soft starters for asynchronous motors

Altistart U01 and TeSys U  
For 0.75 to 15 kW motors

## ATSU 01N2●●LT soft start/soft stop units (continued)

Automatic control with Modbus communication module, with and without deceleration

Without reversing unit

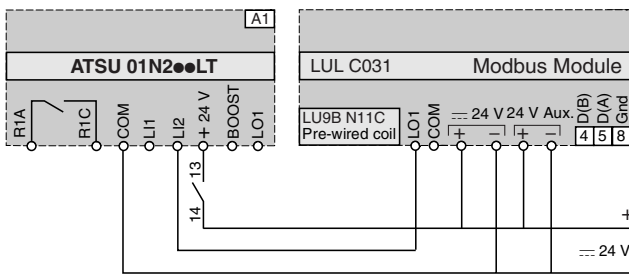

With reversing unit

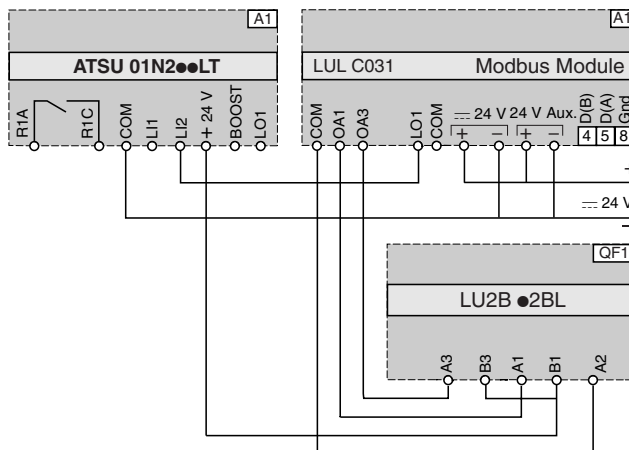

Function	Register	Bit	Value
<b>Powering down TeSys U and ATSU</b>			
-	704	0	0
<b>Automatic control without deceleration</b>			
Run	700	0	1
Stop	704	0	0
<b>Automatic control with deceleration</b>			
Run	700	0	1
Soft stop	700	0	0

Function	Register	Bit	Value
<b>Powering up TeSys U and ATSU</b>			
Forward	704	0	1
Reverse	704	1	1
<b>Powering down TeSys U and ATSU</b>			
Forward	704	0	0
Reverse	704	1	0
<b>Automatic control without deceleration</b>			
Run	700	0	1
Stop forward	704	0	0
Stop reverse	704	1	0
<b>Automatic control with deceleration (forward or reverse)</b>			
Run	700	0	1
Soft stop	700	0	0

A1: Soft start/soft stop unit

A1: Soft start/soft stop unit

QF1: TeSys U controller-starter with reversing unit

## Automatic control with AS-Interface communication module, without deceleration

Without reversing unit

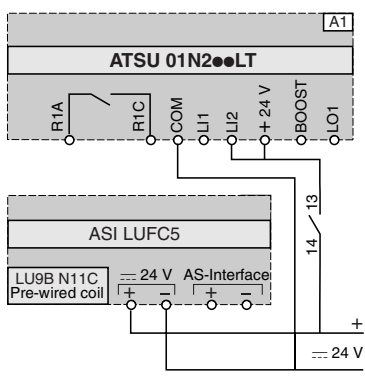

Function	Bit	Value
<b>Power-up and automatic control without deceleration</b>		
Run	D0	1
Stop	D0	0

A1: Soft start/soft stop unit

With reversing unit

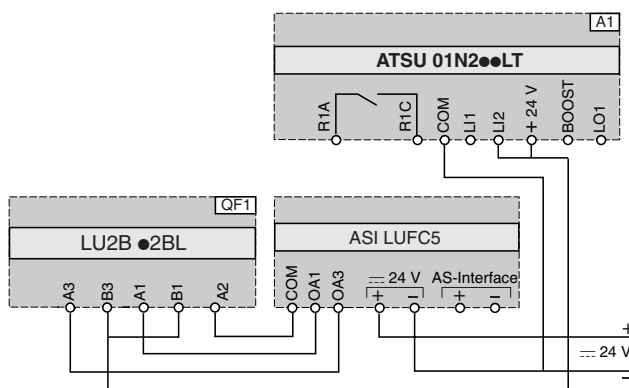

Function	Bit	Value
<b>Power-up and automatic control without deceleration</b>		
Run forward	D0	1
Stop	D0	0
Run reverse	D1	1
Stop	D1	0

A1: Soft start/soft stop unit

QF1: TeSys U controller-starter with reversing unit