

Variable speed drives for asynchronous motors **Altivar 11**

Catalogue
July

2002



Real efficiency
at a reduced size!...



Schneider
 **Electric**
Building a New Electric World

Telemecanique

Variable speed drives for asynchronous motors

Altivar 11

951 250

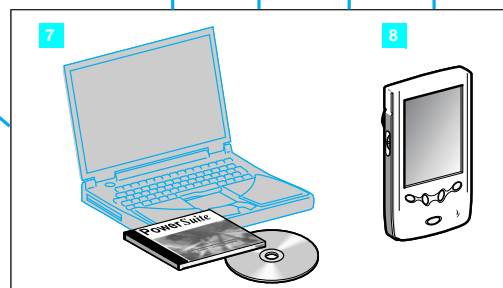
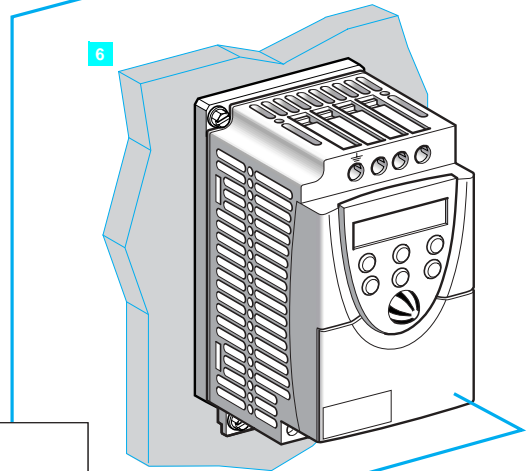
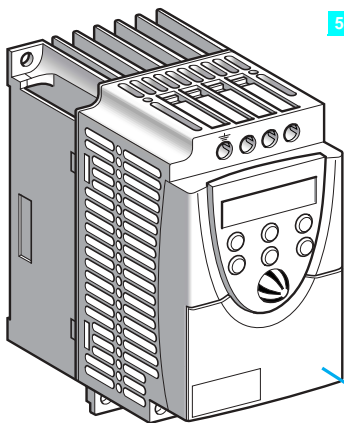
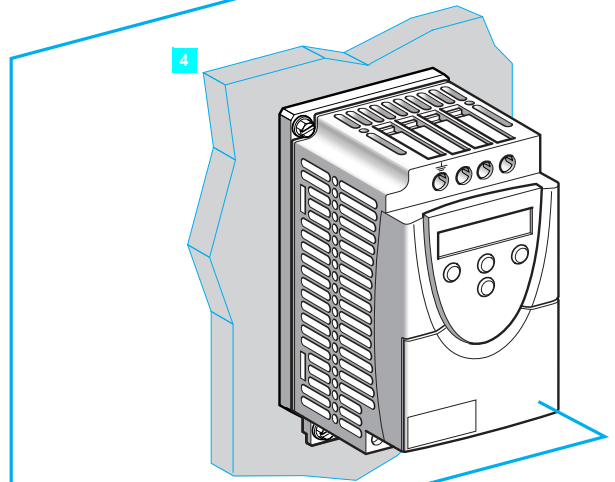
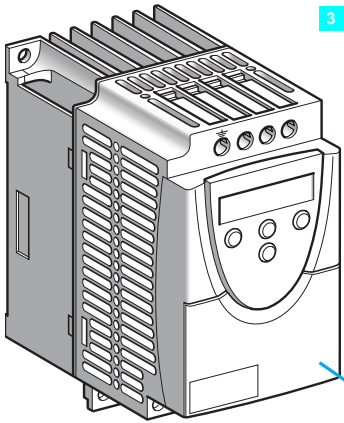
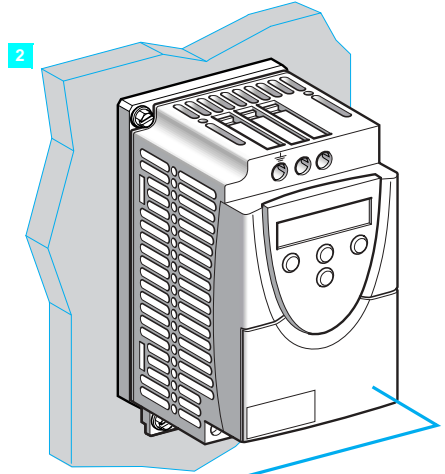
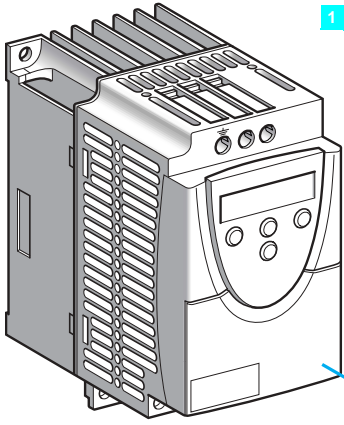

Variable speed drives for asynchronous motors

Altivar 11

Applications

The Altivar 11 is a frequency inverter for 3-phase squirrel cage asynchronous motors rated between 0.18 kW and 2.2 kW.

There are three types of power supply:

- 100 V to 120 V single phase
- 200 V to 240 V single phase
- 200 V to 230 V 3-phase

The Altivar 11 incorporates specific features for local markets (Europe range, America range, Asia range) and has functions suitable for the most common applications, including:

- Horizontal materials handling (small conveyors, etc)
- Ventilation, pumping, access control, automatic doors
- Special machines (mixers, washing machines, centrifuges, etc)

Functions

The main functions incorporated in the Altivar 11 drive are:

- Starting and speed control
- Reversal of operation direction
- Acceleration, deceleration, stopping
- Motor and drive protection
- 2-wire/3-wire control
- 4 preset speeds
- Saving the configuration in the drive
- d.c. injection on stopping
- Ramp switching
- Catching a spinning load
- Local controls (Asia range only)

Several functions can be assigned to one logic input.

Standard versions

The Altivar 11 offer consists of 3 ranges designed for 3 different markets:

- **Europe range: ATV 11●U●●M2E** (items [1](#), [2](#))
 - Single phase 240 V power supply
 - Positive logic operation
 - Integrated class B EMC filter
- **America range: ATV 11●U●●●●U** (items [1](#), [2](#), [3](#), [4](#))
 - Power supplies: 120 V single phase, 240 V single phase or 230 V 3-phase
 - Positive logic operation
 - Meets current requirement in standard NEC 1999 208 V
- **Asia range: ATV 11●U●●●●A** (items [5](#), [6](#))
 - Power supplies: 120 V single phase, 240 V single phase or 230 V 3-phase
 - Positive or negative logic operation
 - Local controls: Run and Stop keys, and potentiometer

Altivar 11 drives are supplied either with heatsink (items [1](#), [3](#), [5](#)) for normal environments and ventilated enclosures, or on a base plate (items [2](#), [4](#), [6](#)) for mounting on a machine frame, when the size of the frame enables dissipation of the heat.

Electromagnetic compatibility EMC

The incorporation of EMC filters in **ATV 11●U●●M2E** drives simplifies installation of machines and provides an economical means of meeting CE marking requirements. **ATV 11●U●●●●U** and **ATV 11●U●●●●A** drives are available without EMC filter. Filters are available as an option for customer assembly, if conformity to EMC standards is required.

Options

The drive only communicates, in point-to-point mode, with the following tools and software:

- PowerSuite advanced dialogue solution :
 - PowerSuite software workshop for configuring the drive (item [7](#)),
 - PowerSuite for Pocket PC (item [8](#)),
 - Converter for connecting a PC or a Pocket PC

The following options can be used with the Altivar 11 drive:

- Braking module connected to the drive's DC bus
- Braking resistors, for dissipating the energy returned to the drive when the motor is operating as a generator
- EMC radio interference input filters
- Plates for mounting on  rail
- Adaptor plate for replacing an Altivar 08 drive
- Plate for EMC mounting, earthing the cable shielding.

Variable speed drives for asynchronous motors

Altivar 11

ATV 11●●●●●●E Europe range



ATV 11 HU18M2E



ATV 11 PU18M2E



ATV 11 HU41M2E

Drives with heatsink (frequency range from 0 to 200 Hz)

Motor	Line supply (1)	Altivar 11		Power dissipated (4)	Reference (4)	Weight
Power indicated on plate	Max. line current for prospective Isc 1 kA	Permanent output current (2)	Max. transient current (3)	at nominal load		
kW	A	A	A	W		kg
Single phase supply voltage: 200...240 V 50/60 Hz						
0.18	2.9	1.1	1.6	12	ATV 11HU05M2E	0.900
0.37	5.3	2.1	3.1	20.5	ATV 11HU09M2E	1.000
0.55	6.3	3	4.5	29	ATV 11HU12M2E	1.100
0.75	8.6	3.6	5.4	37	ATV 11HU18M2E	1.100
1.5	14.8	6.8	10.2	72	ATV 11HU29M2E (5)	1.800
2.2	20.8	9.6	14.4	96	ATV 11HU41M2E (5)	1.800

Drives on base plate (frequency range from 0 to 200 Hz)

Motor	Line supply (1)	Altivar 11		Power dissipated (4)	Reference (4)	Weight
Power indicated on plate	Max. line current for prospective Isc 1 kA	Permanent output current (2)	Max. transient current (3)	at nominal load		
kW	A	A	A	W		kg
Single phase supply voltage: 200...240 V 50/60 Hz						
0.37	5.3	2.1	3.1	20.5	ATV 11PU09M2E	0.900
0.55	6.3	3	4.5	29	ATV 11PU12M2E	0.900
0.75	8.6	3.6	5.4	37	ATV 11PU18M2E	0.900

(1) Line voltage 230 V.

(2) The current value is given for a 4 kHz switching frequency.

(3) For 60 seconds.

(4) Drive supplied with an integrated EMC filter which cannot be disconnected.

(5) With integrated fan.

Variable speed drives for asynchronous motors

Altivar 11

ATV 11●●●●●U America range



ATV 11HU18M2U



ATV 11PU18M2U



ATV 11HU41M2U



ATV 11HU41M3U

Drives with heatsink (frequency range from 0 to 200 Hz)

Motor Power indicated on plate kW/HP	Line supply Max. line current (1) A	Altivar 11			Reference (4)	Weight kg
		Permanent output current (2) A	Max. transient current (3) A	Power dissipated at nominal load W		

Single phase supply voltage: 100...120 V 50/60 Hz

0.18/0.25	6	1.6	2.4	14.5	ATV 11HU05F1U	0.900
0.37/0.5	9	2.4	3.6	23	ATV 11HU09F1U	1.000
0.75/1	18	4.6	6.3	43	ATV 11HU18F1U (5)	1.800

Single phase supply voltage: 200...240 V 50/60 Hz

0.18/0.25	3.3	1.6	2.4	14.5	ATV 11HU05M2U	0.900
0.37/0.5	6	2.4	3.6	23	ATV 11HU09M2U	1.000
0.75/1	9.9	4.6	6.3	43	ATV 11HU18M2U (5)	1.100
1.5/2	17.1	7.5	11.2	77	ATV 11HU29M2U (5)	1.800
2.2/3	24.1	10.6	15	101	ATV 11HU41M2U (5)	1.800

3-phase supply voltage: 200...230 V 50/60 Hz

0.18/0.25	1.8	1.6	2.4	13.5	ATV 11HU05M3U	0.900
0.37/0.5	3.6	2.4	3.6	24	ATV 11HU09M3U	1.000
0.75/1	6.3	4.6	6.3	38	ATV 11HU18M3U (5)	1.100
1.5/2	11	7.5	11.2	75	ATV 11HU29M3U (5)	1.800
2.2/3	15.2	10.6	15	94	ATV 11HU41M3U (5)	1.800

Drives on base plate (frequency range from 0 to 200 Hz)

Motor Power indicated on plate kW/HP	Line supply Max. line current (1) A	Altivar 11			Reference (4)	Weight kg
		Permanent output current (2) A	Max. transient current (3) A	Power dissipated at nominal load W		

Single phase supply voltage: 100...120 V 50/60 Hz

0.37/0.5	9	2.4	3.6	23	ATV 11PU09F1U	0.900
----------	---	-----	-----	----	---------------	-------

Single phase supply voltage: 200...240 V 50/60 Hz

0.37/0.5	6	2.4	3.6	23	ATV 11PU09M2U	0.900
0.75/1	9.9	4.6	6.3	43	ATV 11PU18M2U	0.900

3-phase supply voltage: 200...230 V 50/60 Hz

0.37/0.5	3.6	2.4	3.6	24	ATV 11PU09M3U	0.900
0.75/1	6.3	4.6	6.3	38	ATV 11PU18M3U	0.900

(1) The line current value is given for the measurement conditions indicated in the table below.

Drive rating	Prospective Isc	Line voltage
ATV 11●UF1U	1 kA	100 V
ATV 11●UM2U	1 kA	208 V
ATV 11●UM3U	5 kA	208 V

(2) The current value is given for a 4 kHz switching frequency.

(3) For 60 seconds.

(4) Drive supplied without EMC filter. To order an EMC filter separately, see page 60252/5.

(5) With integrated fan.

Variable speed drives for asynchronous motors

Altivar 11

ATV 11●●●●●●A Asia range

550486



ATV 11HU18M2A

550487



ATV 11PU18M2A

550492



ATV 11HU41M2A

550493



ATV 11HU41M3A

Drives with heatsink (frequency range from 0 to 200 Hz)

Motor Power indicated on plate	Line supply Max. line current (1)	Altivar 11			Reference (4)	Weight
		Permanent output current (2)	Max. transient current (3)	Power dissipated at nominal load		
kW	A	A	A	W		kg

Single phase supply voltage: 100...120 V 50/60 Hz

0.18	6	1.4	2.1	14	ATV 11HU05F1A	0.900
0.37	9	2.4	3.6	25	ATV 11HU09F1A	1.000
0.75	18	4	6	40	ATV 11HU18F1A (5)	1.800

Single phase supply voltage: 200...240 V 50/60 Hz

0.18	3.3	1.4	2.1	14	ATV 11HU05M2A	0.900
0.37	6	2.4	3.6	25	ATV 11HU09M2A	1.000
0.75	9.9	4	6	40	ATV 11HU18M2A	1.100
1.5	17.1	7.5	11.2	78	ATV 11HU29M2A (5)	1.800
2.2	24.1	10	15	97	ATV 11HU41M2A (5)	1.800

3-phase supply voltage: 200...230 V 50/60 Hz

0.18	1.8	1.4	2.1	13.5	ATV 11HU05M3A	0.900
0.37	3.6	2.4	3.6	24	ATV 11HU09M3A	1.000
0.75	6.3	4	6	38	ATV 11HU18M3A	1.100
1.5	11	7.5	11.2	75	ATV 11HU29M3A (5)	1.800
2.2	15.2	10	15	94	ATV 11HU41M3A (5)	1.800

Drives on base plate (frequency range from 0 to 200 Hz)

Motor Power indicated on plate	Line supply Max. line current (1)	Altivar 11			Reference (4)	Weight
		Permanent output current (2)	Max. transient current (3)	Power dissipated at nominal load		
kW	A	A	A	W		kg

Single phase supply voltage: 100...120 V 50/60 Hz

0.37	9	2.4	3.6	25	ATV 11PU09F1A	0.900
------	---	-----	-----	----	---------------	-------

Single phase supply voltage: 200...240 V 50/60 Hz

0.37	6	2.4	3.6	25	ATV 11PU09M2A	0.900
0.75	9.9	4	6	40	ATV 11PU18M2A	0.900

3-phase supply voltage: 200...230 V 50/60 Hz

0.37	3.6	2.4	3.6	24	ATV 11PU09M3A	0.900
0.75	6.3	4	6	38	ATV 11PU18M3A	0.900

(1) The line current value is given for the measurement conditions indicated in the table below.

Drive rating	Prospective Isc	Line voltage
ATV 11●UF1A	1 kA	100 V
ATV 11●UM2A	1 kA	200 V
ATV 11●UM3A	5 kA	200 V

(2) The current value is given for a 4 kHz switching frequency.

(3) For 60 seconds.

(4) Drive supplied without EMC filter. To order an EMC filter separately, see page 60252/5.

(5) With integrated fan.

Variable speed drives for asynchronous motors

Altivar 11



VW3 A5870



VW3 A5873

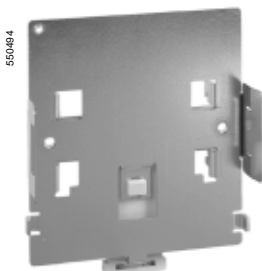

VW3 A11852

Options and accessories

Description	For drives	Reference	Weight kg
Advanced dialogue solution PowerSuite	All ratings	See page 60200/3	–
Converter, for connecting a PC or Pocket PC, equipped with PowerSuite software	All ratings	VW3 A11301	0.070
EMC input filters	ATV 11HU05M2E ATV 11HU09M2E ATV 11HU12M2E ATV 11HU18M2E ATV 11HU05F1U/A ATV 11HU09F1U/A ATV 11HU05M2U/A ATV 11HU09M2U/A ATV 11HU18M2U/A	VW3 A11401	0.650
	ATV 11HU29M2E ATV 11HU41M2E ATV 11HU18F1U/A ATV 11HU29M2U/A ATV 11HU41M2U/A	VW3 A11402	0.850
	ATV 11HU05M3U/A ATV 11HU09M3U/A ATV 11HU18M3U/A	VW3 A11403	0.650
	ATV 11HU29M3U/A ATV 11HU41M3U/A	VW3 A11404	0.850
Braking module connected to the DC bus	All ratings	VW3 A11701	0.250
Braking resistors	Not protected (IP 00)	ATV 11●U05●●● (1) ATV 11●U09●●● (1) ATV 11●U12●●● (1) ATV 11●U18●●● (1) ATV 11●U29●●● (2)	VW3 A58702 0.600
		ATV 11●U41●●● (2)	VW3 A58704 0.600
	Protected (IP 30)	ATV 11●U05●●● (1) ATV 11●U09●●● (1) ATV 11●U12●●● (1) ATV 11●U18●●● (1) ATV 11●U29●●● (2)	VW3 A58732 2.000
		ATV 11●U41●●● (2)	VW3 A58733 2.000
Plates for mounting on \square rail (width 35 mm)	ATV 11●U05●●● ATV 11●U09●●● ATV 11●U12●●● ATV 11●U18M●●	VW3 A11851	0.220
	ATV 11HU18F1● ATV 11●U29●●● ATV 11●U41●●●	VW3 A11852	0.300
Adaptor plate for replacing Altivar 08	All ratings	VW3 A11811	0.220
Earthing plate for EMC mounting	All ratings	VW3 A11831	0.100
Ventilation kit (3)	ATV 11HU18F1● ATV 11HU18M●U ATV 11HU29●●● ATV 11HU41●●●	VW3 A11821	0.070

(1) Minimum value of the resistor to be connected: 75 ohms.

(2) Minimum value of the resistor to be connected: 51 ohms.

(3) "Low noise" fan.

Variable speed drives for asynchronous motors

Altivar 11

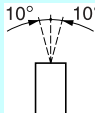
Environment	
Conformity to standards	Altivar 11 drives have been developed to conform to the strictest international standards and the recommendations relating to electrical industrial control devices (IEC, EN), in particular: EN 50178, EMC immunity and EMC conducted and radiated emissions.
EMC immunity	<ul style="list-style-type: none"> ■ IEC/EN 61000-4-2 level 3 ■ IEC/EN 61000-4-3 level 3 ■ IEC/EN 61000-4-4 level 4 ■ IEC/EN 61000-4-5 level 3 (power access) ■ IEC/EN 61800-3, environments 1 and 2
EMC conducted and radiated emissions for drives:	
All	■ IEC/EN 61800-3, environments: 2 (industrial supply) and 1 (public supply) restricted distribution
ATV 11●U05M2E to ATV 11●U18M2E	■ EN 55011, EN 55022 class B, 2 to 12 kHz for motor cable lengths ≤ 5 m and class A (group 1), 2 to 16 kHz for lengths ≤ 10 m
ATV 11●U29M2E to ATV 11●U41M2E	■ EN 55011, EN 55022 class B, 4 to 16 kHz for motor cable lengths ≤ 5 m and class A (group 1), 4 to 16 kHz for lengths ≤ 10 m
ATV 11HU05M2E to ATV 11HU41M2E	■ With additional EMC filter: EN 55011, EN 55022 class B, 2 to 16 kHz for motor cable lengths ≤ 20 m and class A (group 1), 2 to 16 kHz for lengths ≤ 50 m
ATV 11HU05●●U to ATV 11HU41●●U and ATV 11HU05●●A to ATV 11HU41●●A	■ With additional EMC filter: EN 55011, EN 55022 class B, 2 to 16 kHz for motor cable lengths ≤ 5 m and class A (group 1), 2 to 16 kHz for lengths ≤ 20 m
CE marking	The drives bear CE marking in accordance with the European low voltage directives (73/23/EEC and 93/68/EEC) and EMC (89/336/EEC)
Product certification	UL, CSA, NOM 117 and C-TICK
Degree of protection	IP 20
Vibration resistance	Drive without  rail option
Shock resistance	Conforming to IEC/EN 60068-2-6: - 1.5 mm peak from 3 to 13 Hz - 1 gn from 13 to 200 Hz
Ambient temperature around the unit	Storage
	°C - 25...+ 65
	Operation
	°C - 10...+ 40, - 10...+ 50 : removing the protective cover from the top of the drive Up to + 60 with current derating of 2.2% per °C above 50 °C
Maximum operating altitude	m 1000 without derating (above this, derate the current by 1% per additional 100 m)
Operating position	
Drive characteristics	
Output frequency range	Hz 0...200
Switching frequency	kHz 2...16
Speed range	1...20
Transient overtorque	150% of the nominal motor torque
Braking torque	- 20% of the nominal motor torque without braking resistor at no-load with the "deceleration ramp adaptation" function enabled - 80% of the nominal motor torque with braking resistor (available as an option) at no-load - Up to 150% of the nominal motor torque with braking resistor (available as an option) at high inertia
Maximum transient current	150% of the nominal drive current for 60 seconds
Voltage/frequency ratio	Sensorless flux vector control with PWM motor control signal (1) Factory-set for most constant torque applications
Frequency loop gain	Factory-set with the speed loop stability and gain Possible correction for machines with high resistive torque or high inertia, or for machines with fast cycles
Slip compensation	Factory-set, according to the rating of the drive (adjustment possible)

(1) Pulse width modulation

Variable speed drives for asynchronous motors

Altivar 11

Electrical characteristics			
Power supply	Voltage	V	200 - 15% to 240 + 10% single phase for ATV 11●U●●M2● 200 - 15% to 230 + 15% 3-phase pour ATV 11●U●●M3● 100 - 15% to 120 + 10% single phase for ATV 11●U●●F1●
	Frequency	Hz	50 ± 5% or 60 ± 5%
	Isc	A	≤ 1000 (prospective short-circuit current at the connection point) for single phase power supply ≤ 5000 (prospective short-circuit current at the connection point) for 3-phase power supply
Output voltage			Maximum 3-phase voltage equal to: - the line supply voltage for ATV 11●U●●M●● - double the line supply voltage for ATV 11●U●●F1●
Maximum connection capacity of the power supply, the motor and the braking module	Drive ATV 11●U05●●●, U09●●●, U12M●●, U18M●●		1.5 mm ² (AWG 14)
	Drive ATV 11●U18F1●, U29●●●, U41●●●		4 mm ² (AWG 10)
Max. length of motor cables		m	- 50, shielded cable - 100, non-shielded cable
Electrical isolation			Electrical isolation between power and control (inputs, outputs, power supplies)
Available internal supplies			Short-circuit and overload protection: - One + 5 V (0/+ 5%) supply for the reference potentiometer (2.2 to 10 kΩ), maximum current 10 mA - One + 15 V (± 15%) supply for the control inputs, maximum current 100 mA
Analog input AI1			1 configurable analog input Max. sampling time: 20 ms, resolution 0.4%, linearity ± 5%: - voltage 0-5 V (internal power supply only) or 0-10 V, impedance 40 kΩ - current 0-20 mA or 4-20 mA (without addition of a resistor), impedance 250 Ω
Logic inputs LI			4 assignable logic inputs, impedance 5 kΩ + 15 V internal or 24 V external power supply (min. 11 V, max. 30 V). Factory-set with 2-wire control in "transition" mode for machine safety, for Europe and America ranges: - LI1: forward - LI2: reverse - LI3/LI4: 4 preset speeds - Local controls for the Asia range Multiple assignment makes it possible to mix several functions on one input (example: LI1 assigned to forward and preset speed 2 LI3 assigned to reverse and preset speed 3)
		Positive logic	State 0 if < 5 V, state 1 if > 11 V Max. sampling time: 20 ms
		Negative logic	Available by programming on the Asia range only State 0 if > 11 V or logic input not wired, state 1 if < 5 V Max. sampling time: 20 ms
DO output			Factory setting: - 2 kHz PWM (1) open collector output. Can be used for electromagnetic galvanometer - Max. current 10 mA - Output impedance 1 kΩ, linearity ± 1%, max. sampling time 20 ms. Assignable as logic output: - Open collector logic output, output impedance 100 Ω, 50mA max - Internal voltage (see above, available internal supplies) - External voltage 30 V max: 50 mA
Relay outputs (RA-RC)			1 protected relay logic output (contact open on fault). Minimum switching capacity: 10 mA for ~ 24 V. Maximum switching capacity: ■ On resistive load (cos φ = 1 and L/R = 0 ms): 5 A for ~ 250 V or ~ 30 V ■ On inductive load (cos φ = 0.4 and L/R = 7 ms): 2 A for ~ 250 V or ~ 30 V
Maximum I/O connection capacity			1.5 mm ² (AWG 14)
Acceleration and deceleration ramps			Ramp profiles: linear from 0.1 to 99.9 s. Automatic adaptation of deceleration ramp time if braking capacities exceeded, possible inhibition of this adaptation (use of braking module).
Braking to a standstill			By d.c. injection: automatically to a standstill as soon as the frequency drops to zero. Period adjustable from 0.1 to 30 s or continuous, current adjustable from 0 to 1.2 In
Main protection and safety features of the drive			<ul style="list-style-type: none"> ■ Thermal protection against overheating ■ Protection against short-circuits between output phases ■ Protection against overcurrent between output phases and earth, at power-up only ■ Line supply overvoltage and undervoltage safety circuits ■ Line supply phase loss safety function, for 3-phase supply.
Motor protection			Thermal protection integrated in the drive by continuous calculation of the I ² t. Thermal memory reset on power down.
Insulation resistance to earth		MΩ	> 500 (electrical isolation)
Frequency resolution			Display units: 0.1 Hz Analog inputs: 0.1 Hz for 200 Hz max.
Time constant for reference change		ms	5

(1) Pulse width modulation

Torque characteristics (typical curves)

The curves below define the available continuous torque and transient overtorque for both force-cooled and self-cooled motors. The only difference is in the ability of the motor to provide a high continuous torque at less than half the nominal speed.

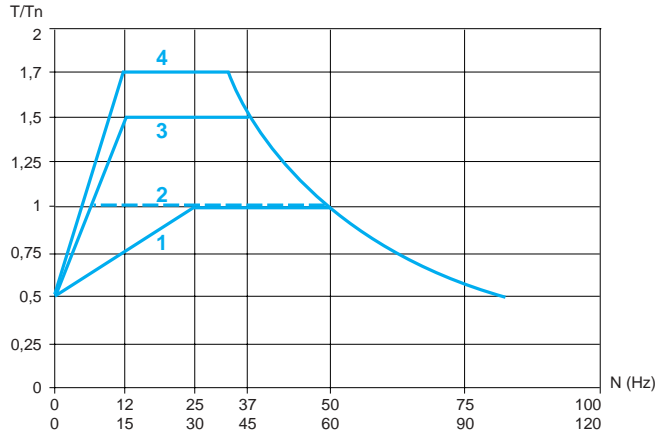

- 1 Self-cooled motor: continuous useful torque
- 2 Force-cooled motor: continuous useful torque
- 3 Transient overtorque in factory settings, when motor is warm.
- 4 Transient overtorque in optimised settings, when motor is warm.

Special uses

Use with a motor with a different rating to that of the drive

The device can supply any motor which has a power rating lower than that for which it is designed.

For motor ratings slightly higher than that of the drive, check that the current absorbed does not exceed the permanent output current of the drive.

Connecting motors in parallel

The rating of the drive must be greater than or equal to the sum of the currents of the motors to be connected to the drive. In this case, provide external thermal protection for each motor using thermal probes or relays.

If the number of motors in parallel is greater than or equal to 3, it is advisable to install a 3-phase choke between the drive and the motors.

Note: For the references of the chokes, please consult your Regional Sales Office.

Variable speed drives for asynchronous motors

Altivar 11

Combinations for self-assembly

Function: to protect persons and equipment from any level of overcurrent which may be encountered (overload or short-circuit).

Standard power ratings of 3-phase 4-pole 50/60 Hz motors	Speed drive Reference (1)	Circuit-breaker			Contactor Reference
		Telemecanique (2)	Adjustment range	Max. short-circuit current Icu	
		Merlin Gerin	Rating		
kW			A	kA	
M1	A1	Q1			KM1
Single-phase supply voltage: 100...120 V 50/60 Hz					
0.18	ATV 11HU05F1●	GV2 ●●14 DT40	6...10 10	> 100 6	LC1 D09 LC1 D09
0.37	ATV 11●U09F1●	GV2 ●●14 DT40	6...10 16	> 100 6	LC1 D12 LC1 D12
0.75	ATV 11HU18F1●	GV2 ●●21 DT40	17...23 20	50 6	LC1 D25 LC1 D25
Single-phase supply voltage: 200...240 V 50/60 Hz					
0.18	ATV 11HU05M2●	GV2 ●●08 DT40	2.5...4 6	> 100 6	LC1 D09 LC1 D09
0.37	ATV 11●U09M2●	GV2 ●●14 DT40	6...10 10	> 100 6	LC1 D09 LC1 D09
0.55	ATV 11●U12M2E	GV2 ●●14 DT40	6...10 10	> 100 6	LC1 D09 LC1 D09
0.75	ATV 11●U18M2●	GV2 ●●16 DT40	9...14 16	> 100 6	LC1 D12 LC1 D12
1.5	ATV 11HU29M2E	GV2 ●●20 DT40	13...18 20	50 6	LC1 D25 LC1 D25
1.5	ATV 11HU29M2U ATV 11HU29M2A	GV2 ●●21 DT40	17...23 20	50 6	LC1 D25 LC1 D25
2.2	ATV 11HU41M2●	GV2 ●●22 DT40	20...25 32	50 6	LC1 D32 LC1 D32
3-phase supply voltage: 200...230 V 50/60 Hz					
0.18	ATV 11HU05M3●	GV2 ●●07 DT40	1.6...2.5 6	> 100 6	LC1 D09 LC1 D09
0.37	ATV 11●U09M3●	GV2 ●●08 DT40	2.5...4 6	> 100 6	LC1 D09 LC1 D09
0.75	ATV 11●U18M3●	GV2 ●●14 DT40	6...10 10	> 100 6	LC1 D09 LC1 D09
1.5	ATV 11HU29M3●	GV2 ●●16 DT40	9...14 16	> 100 6	LC1 D12 LC1 D12
2.2	ATV 11HU41M3●	GV2 ●●20 DT40	13...18 20	50 6	LC1 D25 LC1 D25

Combinations of circuit-breakers and add-on modules

DT40	Vigi TG40		
Rating (A)	Rating (A)	Type (3)	Sensitivity
6	25	A "si"	30 mA
10	25	A "si"	30 mA
16	25	A "si"	30 mA
20	25	A "si"	30 mA
32	40	A "si"	30 mA

Recommendations for special uses:

■ All RH10 / RH21 / RH99 / RHU residual current protection devices with separate sensors are compatible as long as the type and sensitivity of the add-on modules given in the table above are observed.

■ It is advisable to connect one residual current differential safety device per drive. In this case a type B device must not be located downstream of a type A or AC device.

(1) Replace the dots in the reference according to the type of drive required, see pages 60252/2 to 60252/4.

(2) Replace the dots with ME for pushbutton control or with P for control via rotating knob.

Type 2 coordination is provided by combining a GV2 circuit breaker with an LC1 D●● contactor.

(3) For additional protection against direct contact, the add-on module must be type B with a sensitivity of 30 mA, if the following conditions are met :

- 3-phase power supply, all neutral point connection systems and
- the braking resistor must be accessible.

ATV 11HU05●●E/U/A, ATV 11PU●●●●E/U/A

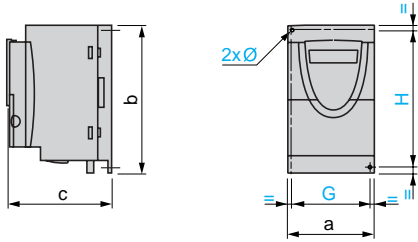

ATV 11	a	b	c	G	H	Ø
HU05●●E/U, PU●●●●E/U	72	142	101	60±1	131±1	5
HU05●●A, PU●●●●A	72	142	108	60±1	131±1	5

ATV 11HU09●●U/A

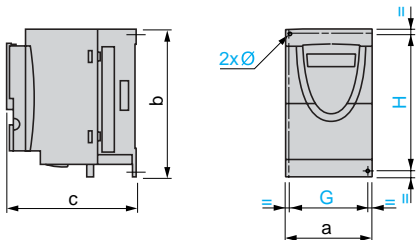

ATV 11	a	b	c	G	H	Ø
HU09●●U	72	142	125	60±1	131±1	5
HU09●●A	72	142	132	60±1	131±1	5

ATV 11HU18M●U/A

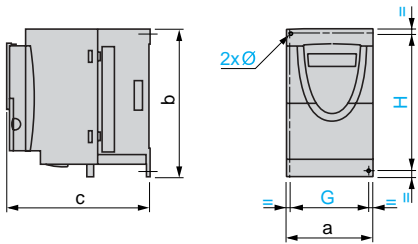

ATV 11	a	b	c	G	H	Ø
HU18M●U	72	147	138	60±1	131±1	5
HU18M●A	72	142	145	60±1	131±1	5

EMC input filters VW3 A11401 to A11404

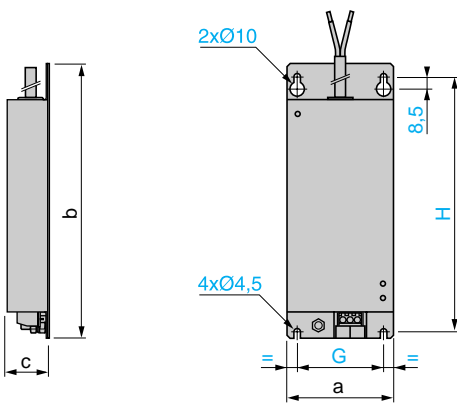

VW3	a	b	c	G	H
A11401	75	194	30	61	180
A11402	117	184	40	97	170
A11403	75	194	40	61	180
A11404	117	190	40	97	170

ATV 11HU09M2E

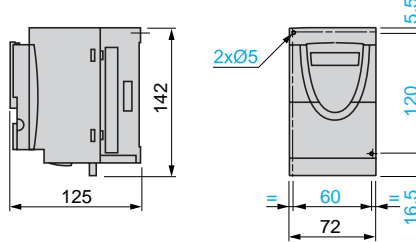

ATV 11HU12M2E, ATV 11HU18M2E

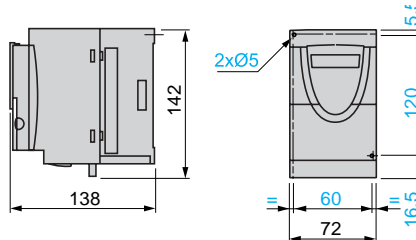

ATV 11HU18F1U/A, ATV 11HU29M●E/U/A, ATV 11HU41M●E/U/A

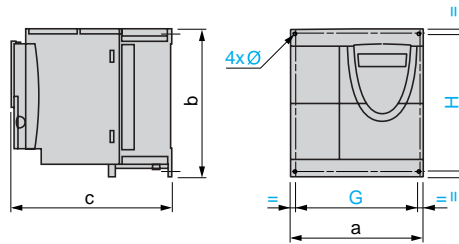

ATV 11	a	b	c	G	H	Ø
HU18F1U, HU29M●E/U, HU41M●E/U	117	142	156	106±0,5	131±1	5
HU18F1A, HU29M●A, HU41M●A	117	142	163	106±0,5	131±1	5

**Protected braking resistors
VW3 A58732 and A58733**

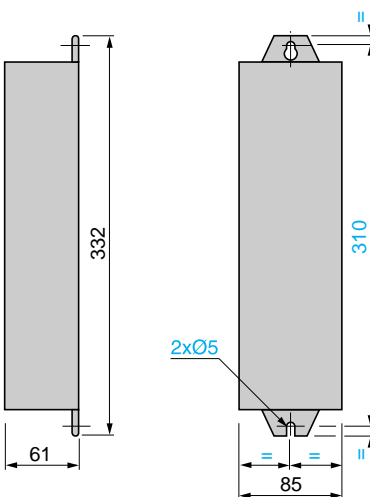

**Non protected braking resistors VW3
A58702 and A58704**

(2-wire output, length 0.5 m)

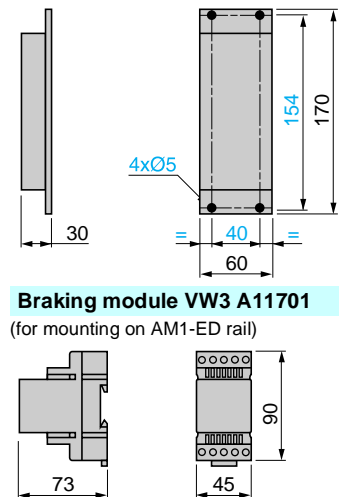

Braking module VW3 A11701

(for mounting on AM1-ED rail)

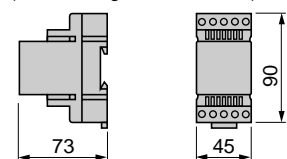

ATV 08 adaptor plate VW3 A11811

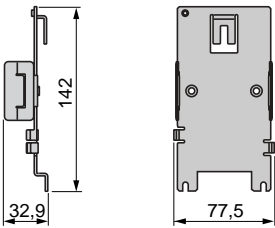

EMC earthing plate VW3 A11831

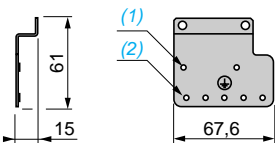

(1) 2 screws supplied for fixing the earthing plate.
(2) 5 x Ø 4 mm screws for fixing EMC clamps.

Mounting recommendations

- Install the unit vertically, at $\pm 10^\circ$.
- Do not place it close to heating elements.
- Leave sufficient free space to ensure that the air required for cooling purposes can circulate, by natural convection or by ventilation, from the bottom to the top of the unit.
- Free space in front of unit: 10 mm minimum.

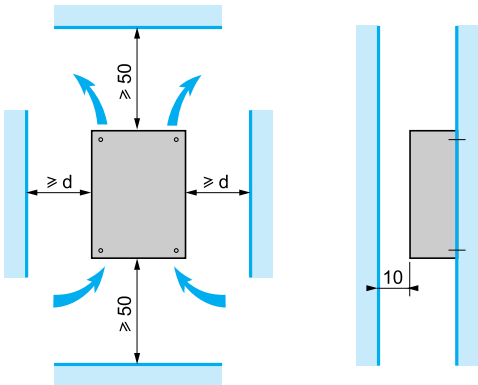

-10 °C to 40 °C

$d \geq 50$ mm: no special precautions.

$d = 0$ (mounted side by side): remove the protective cover from the top of the drive

40 °C to 50 °C

$d \geq 50$ mm: remove the protective cover from the top of the drive

50 °C to 60 °C

$d \geq 50$ mm: remove the protective cover from the top of the drive, and derate the nominal current of the drive by 2.2% per °C above 50 °C.

Recommendations for mounting on a machine frame (specific to ATV 11P●●●●● drives)

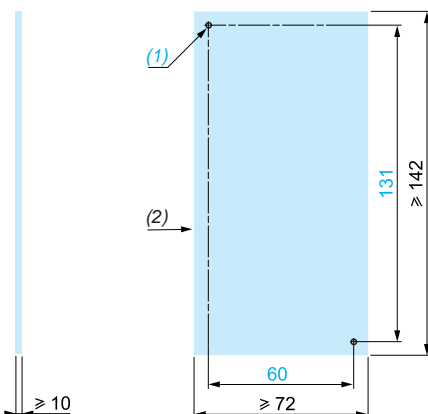

(1) 2 x Ø M5 tapped holes.
(2) Minimum machined area

ATV 11P●●●●● drives can be mounted on (or in) a steel or aluminium machine frame, observing the following conditions:

- Maximum ambient temperature: 40 °C
- Vertical mounting $\pm 10^\circ$
- The drive must be fixed at the centre of a support (frame) which is a minimum of 10 mm thick and with a minimum cooling area of 0.12 m² for steel and 0.09 m² for aluminium, exposed to the open air.
- Support area for the drive (142 x 72 min) machined on the frame with a surface smoothness of 100 µm max and an unevenness of 3.2 µm max
- Mill the tapped holes lightly in order to remove any burrs.
- Coat the whole drive support area with thermal contact grease (or equivalent).

When the operating conditions are close to the maximum limits (power, cycle and temperature), this type of use must be checked beforehand, by monitoring the thermal state of the drive.

Variable speed drives for asynchronous motors

Altivar 11

Schemes with contactor

3-phase power supply ATV 11●●●●M3●

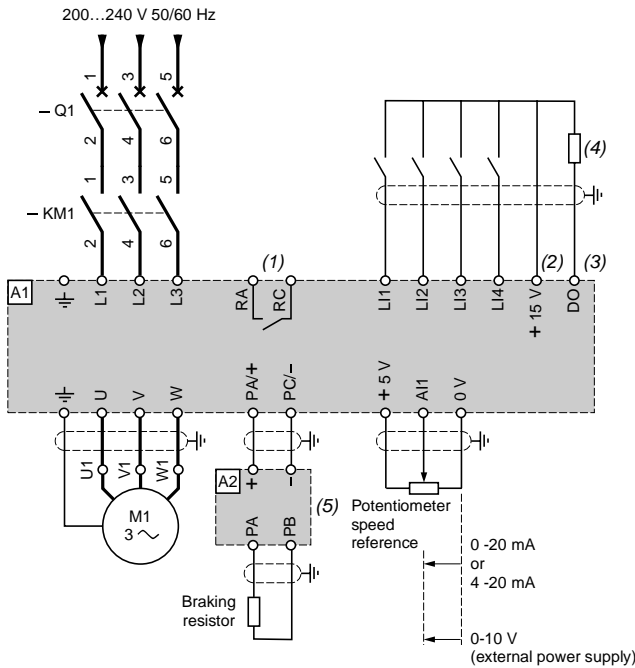

Single phase power supply ATV 11●●●●F1● and ATV 11●●●●M2●

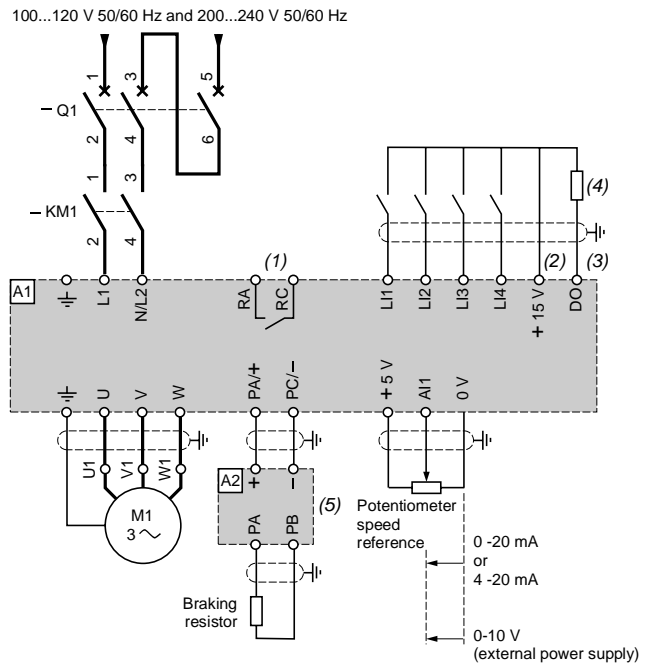

2-wire control

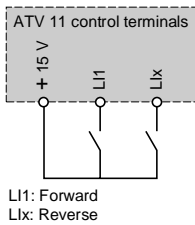

3-wire control

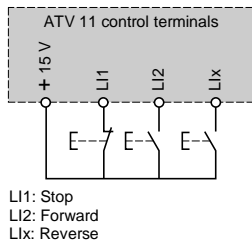

Analog voltage input

External 10 V use

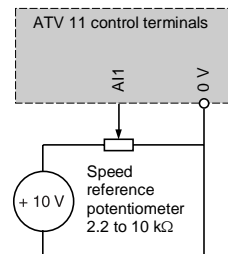

Analog current input

0-20 mA or 4-20 mA

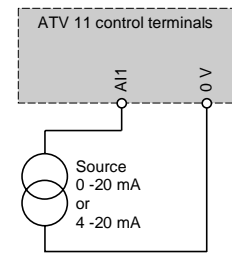

For combinations of KM1, Q1, etc, components (see the table on page 60251/5).

(1) Fault relay contact: for remote signalling of drive status.

(2) Internal +15 V. If an external +24 V supply is used, connect the 0 V on the external supply to the 0 V terminal, do not use the +15 terminal on the drive, and connect the common of the LI inputs to the +24 V of the external supply.

(3) DO output: can be configured as an analog or a logic output. Internal voltage +15 V or external +24 V.

(4) Galvanometer or low level relay.

(5) Braking module VW3 A11701, if braking resistor VW3 A587●● is used.

Note: Fit interference suppressors to all inductive circuits near the drive or connected on the same circuit, such as relays, contactors, solenoid valves, fluorescent lighting, etc.

Connections to meet the requirements of EMC standards

Principle

- Earths between the drive, the motor and the cable shielding must have "high frequency" equipotentiality.
- Use shielded cables with shielding connected to earth at 360° at both ends for the motor cables, and if necessary the braking module and resistor and control-signalling cables. Conduit or metal ducting can be used for part of the shielding length provided that there is no break in continuity.
- Ensure maximum separation between the power supply cable (line supply) and the motor cable.

Installation diagram for ATV 11●U●●●●E/U/A

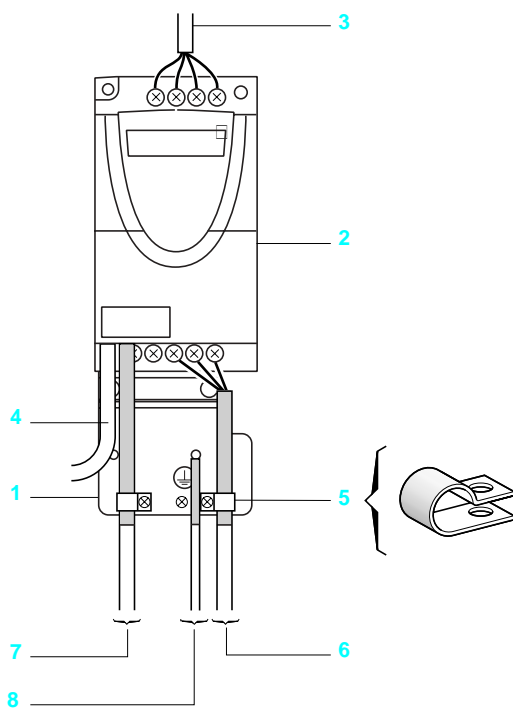

- 1 Earthing plate VW3 A11831 to be fitted on the drive.
- 2 Altivar 11
- 3 Non-shielded power supply cable.
- 4 Non-shielded cable for fault relay contacts output.
- 5 Fix and earth the shielding of cables 6 and 7 as close as possible to the drive:
 - strip the shielding
 - use cable clamps of an appropriate size on the parts from which the shielding has been stripped, to attach them to the earthing plate.
 - the shielding must be clamped tightly enough to the earthing plate to ensure good contact
 - types of clamp: non-oxidizing metal
- 6 Shielded cable (1) for connecting the motor.
- 7 Shielded cable (1) for connecting the control/signalling system. For applications which require a large number of conductors, small cross-sections must be used (0.5 mm²).
- 8 PE cable.

(1) The shielding of cables (6, 7 and 8) must be connected to earth at both ends. The shielding must be continuous and if intermediate terminals are used, they must be in EMC metal boxes.

Note: If using an additional input filter, it must be mounted under the drive and connected directly to the line supply via a non-shielded cable. Link 3 on the drive is then via the filter output cable.

Although there is an HF equipotential earth connection between the drive, the motor and the cable shielding, it is still necessary to connect the PE protective conductors (green-yellow) to the appropriate terminals on each of the devices.

Variable speed drives for asynchronous motors

Altivar 11

Summary of functions

Operating speed range	page 60255/3
Acceleration and deceleration ramp times	page 60255/3
Second ramp	page 60255/3
Deceleration ramp adaptation	page 60255/3
Preset speeds	page 60255/4
Configuration of analog input AI1	page 60255/4
Analog or logic output DO	page 60255/4
Forward/reverse operation	page 60255/4
2-wire control	page 60255/5
3-wire control	page 60255/5
Automatic d.c. injection	page 60255/5
Switching frequency, noise reduction	page 60255/5
Fault relay, unlocking	page 60255/5
Fault reset	page 60255/6
Automatic restart	page 60255/6
Automatic catching a spinning load with speed detection	page 60255/6
Controlled stop on loss of line supply	page 60255/6
Drive thermal protection	page 60255/6
Motor thermal protection	page 60255/6
Monitoring	page 60255/7
Incompatible functions	page 60255/7
Functions specific to the Asia range	page 60255/7

Drive factory setting

To facilitate the setting up of the drive, the functions have been programmed to meet the requirements of the most common applications.

Drive functions and I/O :

- 2-wire control on transition
- Logic input LI1 : forward
- Logic input LI2 : reverse
- Preset speeds:
 - Logic input LI3 : preset speeds
 - Logic input LI4 : preset speeds
- Analog input AI1 : 0-5 V speed reference
- Logic/analog output DO : motor frequency (analog)
- Deceleration ramp adaptation
- Automatic d.c. current injection for 0.5 s to standstill.

Functions of the display and the keys

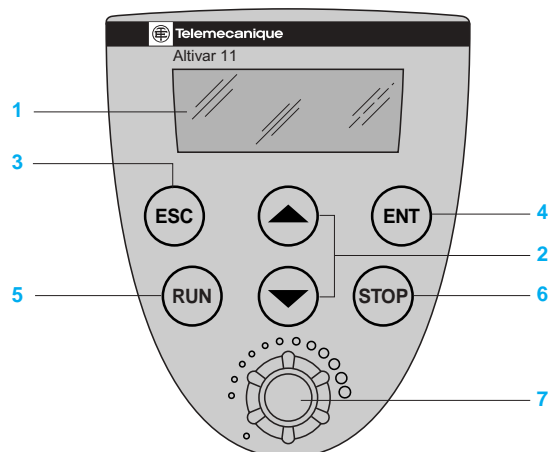

- 1 Information is displayed in the form of codes or values in three "7-segment" displays
 - 2 Buttons for scrolling through the menus or modifying values
 - 3 "ESC" : Button for exiting the menus (no confirmation).
 - 4 "ENT" : Validation button for entering a menu or confirming the new value selected
- Only on the Asia range:
 - 5 "RUN" : Local control of motor operation.
 - 6 "STOP" : Local control of motor stopping.
 - 7 Speed reference potentiometer.

Variable speed drives for asynchronous motors

Altivar 11

■ Operating speed range

Used to determine 2 frequency limits which define the speed range permitted by the machine under actual operating conditions.

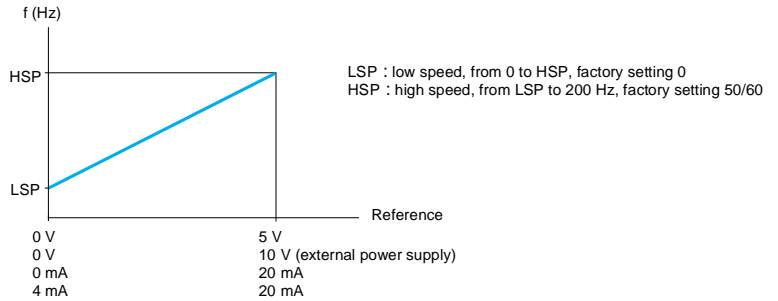

■ Acceleration and deceleration ramp times

Used to define acceleration and deceleration ramp times according to the application and the machine dynamics

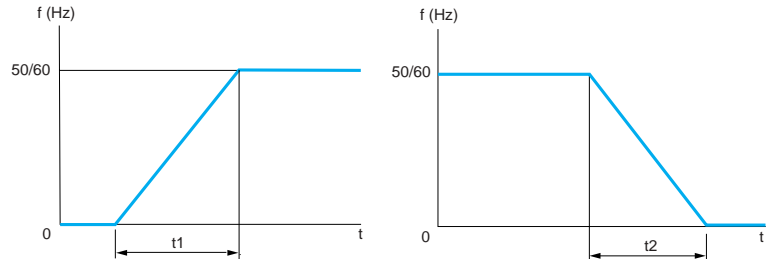

Linear acceleration ramp
Adjustment of t1 : 0.1 to 99.9 s
factory setting 3 s.

Linear deceleration ramp
Adjustment of t2 : 0.1 to 99.9 s
factory setting 3 s.

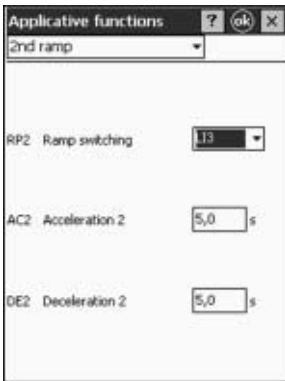

Adjustment of second ramp with Pocket PC PowerSuite

■ Second ramp

Used to switch 2 acceleration or deceleration ramp times, which can be adjusted separately. Enabled by means of 1 reassignable logic input. It is suitable for machines with fast continuous speed correction and high speed lathes with acceleration and deceleration limiting above certain speeds.

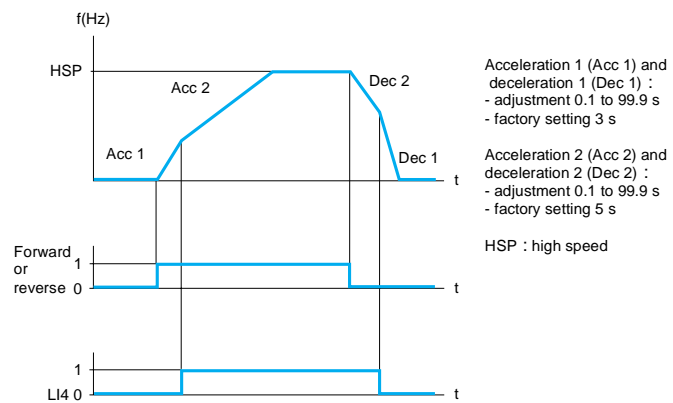

Example of switching using logic input LI4

■ Deceleration ramp adaptation

Used to automatically increase the deceleration ramp time if the initial setting is too low when the load inertia is taken into account. This function prevents the drive locking if there is an **overvoltage on deceleration** fault. If this function is disabled, an appropriate braking module and resistor can be used.

Variable speed drives for asynchronous motors

Altivar 11

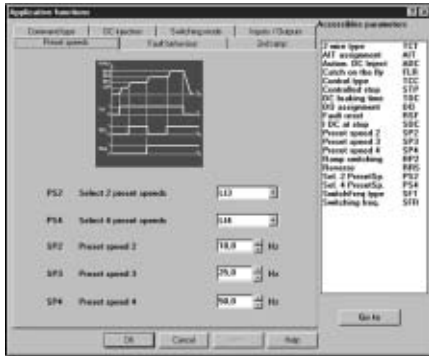

Adjusting the preset speeds with the PowerSuite software workshop for PC

■ Preset speeds

Used to switch preset speed references.
Choice between 2 or 4 preset speeds.

Enabled via 1 or 2 logic inputs.

The preset speeds can be adjusted in increments of 0.1 Hz from 0 Hz to 200 Hz.

They take priority over the reference given via the analog input or, for the Asia range, on the drive's potentiometer.

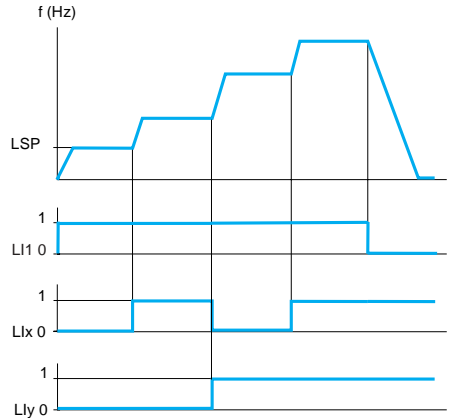

The speed obtained with inputs L1x and L1y at state 0 is LSP or the speed reference, depending on the level of analog input AI1.

Factory settings :

1st speed : LSP (low speed or reference)

2nd speed : 10 Hz

3rd speed : 25 Hz

4th speed : 50 Hz

Example of operation with 4 preset speeds.

■ Configuration of analog input AI1

This is used to modify the specifications, for either voltage or current, of analog input AI1.

Factory setting : 0-5 V (internal power supply only).

Other possible values via external power supplies : 0-10 V, 0-20 mA, 4-20 mA.

Analog voltage input

External 10 V use

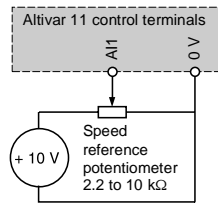

Analog current input

0-20 mA or 4-20 mA use

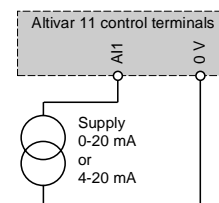

■ Analog or logic output DO

Output DO can be programmed to be a logic output or an analog output. It enables remote signalling of the following information as required :

- Frequency threshold reached (logic output)
- Reference reached (logic output)
- Current threshold reached (logic output)
- Current in the motor (analog output)
- Motor frequency (analog output)

Diagram with internal power supply

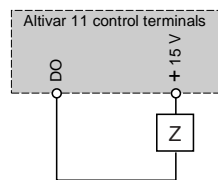
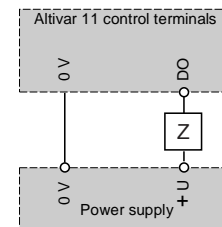

Diagram with external power supply



If it is a logic output: Z is a relay or a low level input.

If it is an analog output: Z can be, for example, a galvanometer.

For a galvanometer with resistance R, the maximum voltage supplied will be :

$$U \times \frac{R(\Omega)}{R(\Omega) + 1000(\Omega)}$$

■ Direction of operation : forward/reverse

In 2-wire control, forward operation cannot be reassigned to any logic input other than LI1.

In 3-wire control, stopping cannot be reassigned to any logic input other than LI1, and forward operation cannot be reassigned to any logic input other than LI2.

Reverse operation can be disabled for applications with a single direction of motor rotation, by not assigning any logic input to reverse operation.

Variable speed drives for asynchronous motors

Altivar 11

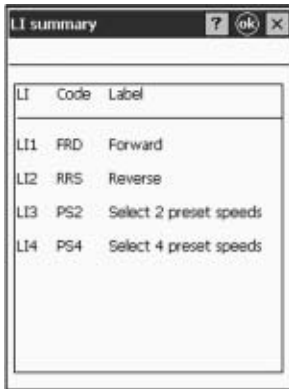

Assignment of logic inputs with Pocket PC PowerSuite

2-wire control

Used to control the direction of operation by means of a maintained contact. Run (forward or reverse) and stop are controlled by the same logic input. Enabled by means of 1 or 2 logic inputs (one or two directions). This function is suitable for all non-reversing and reversing applications.

3 operating modes are possible :

- detection of the state of the logic inputs
- detection of a change in state of the logic inputs
- detection of the state of the logic inputs with forward operation always having priority over reverse

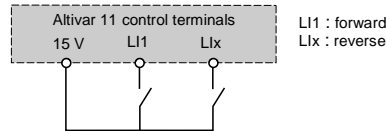

Wiring diagram for 2-wire control

3-wire control

Used to control the operating direction and stopping by means of pulsed contacts. Run (forward or reverse) and stop are controlled by 2 different logic inputs. Enabled by means of 2 or 3 logic inputs (non-reversing or reversing). This function is suitable for all non-reversing and reversing applications.

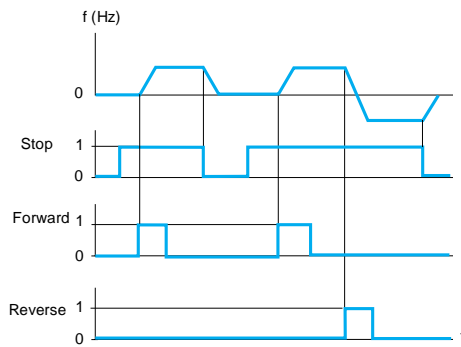

Example of operation with 3-wire control

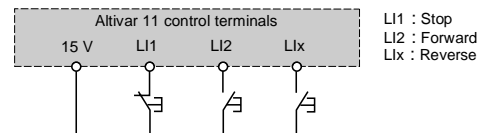

Wiring diagram for 3-wire control

Automatic d.c. injection

Enables d.c. injection to standstill, which is adjustable from 0 to 1.2 times the value of the drive nominal current (preset at 0.7 In), as soon as operation is no longer controlled and the motor speed is zero,

- either for a period of time, which is adjustable from 0.1 to 30 s (preset at 0.5 s)
- or continuously.

Factory setting : function active with d.c. injection for 0.5 s.

In 3-wire control, d.c. injection is only active if logic input LI1 is active (stop).

Switching frequency, noise reduction

High frequency switching of the intermediate d.c. voltage can be used to supply the motor with a current wave with low harmonic distortion.

There are 3 ranges of switching frequency :

- Random switching frequency around 2 or 4 kHz (avoids resonance)
- Fixed low frequency adjustable to 2 or 4 kHz
- Fixed high frequency adjustable to 8, 12 or 16 kHz

Factory setting : Low frequency set at 4 kHz.

This function is suitable for all applications which require low motor noise.

Fault relay, unlocking

The fault relay is energised when the drive is powered up and is not faulty. It opens in the event of a fault or when the drive is powered down.

The drive can be unlocked after a fault in one of the following ways :

- powering down the drive until the display disappears completely, then powering back up
- activating the logic input associated with the "fault reset" function, if the function is enabled
- enabling the "automatic restart" function.

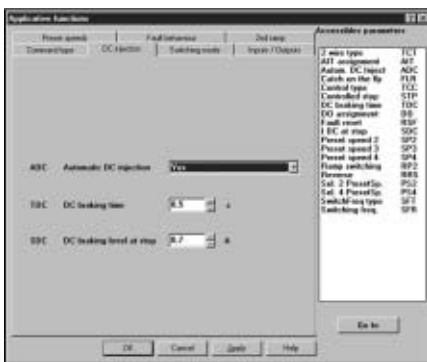

Adjustment of the "d.c. injection" function using the PowerSuite software workshop for PC

Variable speed drives for asynchronous motors

Altivar 11

■ Fault reset

Used to clear the stored fault and restart the drive if the cause of the fault has disappeared. The fault is cleared by a transition of the logic input LI which is assigned to this function. Factory setting : function inactive. The restart conditions after a reset to zero are the same as those of a normal power-up. The following faults can be reset : drive thermal overload, motor thermal overload, line supply overvoltage, overvoltage on deceleration, overspeed, line phase loss (1), line supply undervoltage (2).

■ Automatic restart

Enables the drive to be restarted automatically after locking following a fault if this fault has disappeared and if the other operating conditions permit a restart. This restart is performed by a series of automatic attempts separated by increasingly longer waiting periods: 1 s, 5 s, 10 s, then 1 minute for the following periods. If the drive has not restarted after 6 minutes, the drive locks and the procedure is abandoned until the drive is powered down and back up again. Factory setting : function inactive.

Restart authorised with the following faults : drive thermal overload, motor thermal overload, line supply overvoltage, overvoltage on deceleration, line phase loss (1), line supply undervoltage (2).

If the function is enabled, the drive's safety relay remains activated until one of these faults appears. This function requires the speed reference and the direction of operation to be maintained, and is only compatible with 2-wire level control. This function is suitable for machines or installations in continuous operation or without monitoring, and where a restart will not endanger equipment or personnel in any way.



Adjustment of the behaviour at a fault with Pocket PC PowerSuite

■ Automatic catching a spinning load with speed detection ("catch on the fly")

Used to restart the motor smoothly after one of the following events:
 loss of line supply or power down
 fault reset or automatic restart
 "freewheel stop" triggered by a fault.
 On restarting, the effective speed of the motor is detected in order to restart on the ramp at this speed and return to the reference speed. The speed detection time can be up to 1 s depending on the initial deviation. Factory setting : function inactive.

This function requires the activation of 2-wire level control and is not compatible with the continuous d.c. injection function. This function is suitable for machines for which the loss of motor speed is negligible during the line supply loss time (machines with high inertia).

■ Controlled stop on loss of line supply

Used to define the drive stopping modes at a "loss of line supply" fault. **Three stopping modes are available for selection :**
 "Freewheel" stop : the drive is locked and the motor stops in accordance with the inertia and the resistive torque
 Normal stop : stop with valid deceleration ramp time (deceleration 1 or 2).
 Fast stop : the stopping time depends on the inertia and the braking ability of the drive.

Factory setting : "Freewheel" stop.

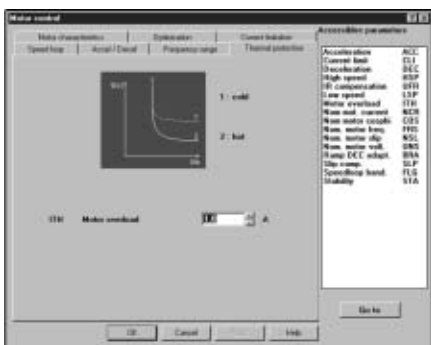
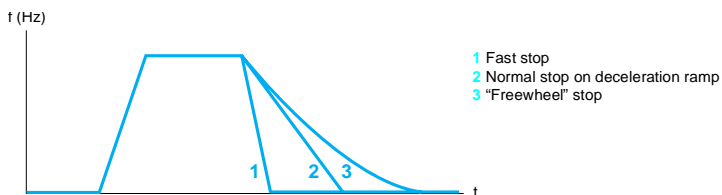

Adjusting the thermal protection with the PowerSuite software workshop for PC

■ Thermal protection of drive

Direct protection by thermistor, integrated in the drive's power module. This protects the components, even in the event of poor ventilation or excessive ambient temperature. When the fault is detected, it locks the drive.

■ Motor thermal protection

Motor thermal protection is implemented via continuous calculation of its theoretical temperature rise. The drive is locked on a fault if this temperature rise exceeds 118% of the nominal temperature rise. This function is suitable for applications with self-cooled or force-cooled motors.

Note: The thermal state of the motor is not stored when the drive is powered down.

- (1) The line supply phase loss fault is only accessible on drives with 3-phase power supply, if monitoring of the fault has been enabled (Factory setting : enabled).
- (2) The drive will restart as soon as the undervoltage fault disappears, whether or not the function is active.

Variable speed drives for asynchronous motors

Altivar 11

■ Monitoring

The display shows the state of the drive or, if selected, one of the following values :

- Frequency reference
- Output frequency applied to the motor
- Motor current
- Line voltage
- Motor thermal state
- Drive thermal state

Incompatible functions

The choice of the last function configured is enabled, whatever the configuration of the previous functions.

Application functions can be assigned to the same logic input, in which case one logic input enables a number of functions (for example : direction of operation and 2nd ramp).

A check must be carried out to ensure that the functions are compatible.

■ **Direction of operation and 2-wire control** : forward operation can only be assigned to LI1.

■ **Direction of operation and 3-wire control** : forward operation can only be assigned to LI2.

■ **Automatic restart** : requires the configuration of 2-wire level control. Changing the configuration of the type of control disables automatic restart.

■ **Automatic catching a spinning load with speed detection** :

requires the configuration of 2-wire level control. Changing the configuration of the type of control disables automatic catching a spinning load.

not compatible with continuous d.c. injection braking to a standstill. Configuring this function disables automatic catching a spinning load.

Functions specific to the Asia range

■ Local control :

The keypad on the Asia range has 2 additional keys (RUN and STOP) and a potentiometer (speed reference).

The keys and the potentiometer are active if local control is enabled.

The logic and analog inputs are inactive if local control is enabled.

Factory setting : function active.

Reverse : if local control is active, the reverse function is not visible.

■ Logic inputs :

It is possible to choose the active level of the logic input.

Positive logic : the inputs are active if the signal is ≥ 11 V.

Negative logic : the inputs are active if the signal is ≤ 5 V.

Factory setting : positive logic.