

Automation and control

Soft starters and variable speed drives

Catalogue

2007/2008



Variable speed drives for asynchronous motors Altivar 21

2

2.2



Ventilation application



Air conditioning application



Pumping application

Applications

The Altivar 21 drive is a frequency inverter for 0.75 kW to 75 kW three-phase asynchronous motors.

It has been designed for state-of-the-art applications in heating, ventilation and air conditioning (HVAC) in the service industry:

- Ventilation
- Air conditioning
- Pumping

The Altivar 21 drive considerably improves building management by:

- Providing a significant energy saving
- Simplifying circuits by removing valves and flow control gates
- Reducing noise pollution
- Offering flexibility and ease of adjustment for installations

The Altivar 21 drive was designed to ensure electromagnetic compatibility and to reduce current harmonics.

Its various design versions make it possible to reduce installation costs by offering EMC class A or class B filters with the following advantages:

- More compact size
- Simplified wiring, thus reduced cost

The Altivar 21 drive is easily integrated into building management as it offers several communication cards:

- LONWORKS
- BACnet
- METASYS N2
- APOGEE FLN

Functions

The Altivar 21 drive makes immediate operation of your applications possible as well as allowing settings to be changed quickly via the "Quick menu".

Functions designed specifically for pumping and ventilation applications

The Altivar 21 drive combines all the functions that your applications require:

- Energy saving ratio, quadratic voltage/frequency ratio
- Automatic catching of a spinning load with speed detection
- Adaptation of current limiting according to speed
- Noise and resonance suppression by means of the switching frequency, which is adjustable up to 16 kHz during operation
- Preset speeds
- Integrated PID regulator with preset references and automatic/manual ("Auto/Man.") mode
- Electricity and service hours meter
- Switching of command channels (references and run command) using the LOC/REM key
- Sleep/wake-up function
- Automatic ramp adaptation
- Ramp switching
- Reference calibration and limitation
- Switching of two motor rating plates

Protection functions

The Altivar 21 drive combines all the protection functions that your applications require:

- Motor and drive thermal protection, PTC thermal probe management
- Protection against overloads and overcurrents in continuous operation
- Machine mechanical protection via jump frequency function
- Protection of the installation by means of underload and overload detection
- Protection via multiple fault management and configurable alarms

Service continuity

Installation safety is assured by means of the forced operation function with inhibition of faults, direction of operation and configurable references.

Variable speed drives for asynchronous motors

Altivar 21



ATV 21HD75N4



ATV 21H075M3X



ATV 21WD18N4,
ATV 21WD18N4C



ATV 21W075N4,
ATV 21W075N4C

Flexibility and user-friendliness

The Altivar 21 drive has an integrated 7-segment display terminal. This terminal is used to identify and determine the active command channels (run command and speed reference).

It also enables:

- Direct access to the last five modified parameters
- Identification of the different factory-set parameters in the form of a list in a menu
- Backup of the customer configuration

The Altivar 21 drive offers a quick setup function in the form of its “Quick menu”, which includes the 10 key parameters for your installation (acceleration, deceleration, motor parameters, etc.).

A comprehensive offer

The Altivar 21 range of variable speed drives extends across a range of motor power ratings from 0.75 kW to 75 kW with the following types of power supply:

- 200...240 V three-phase, 0.75 kW to 30 kW, UL type 1/IP 20, (ATV 21H●●●M3X)
- 380...480 V three-phase, 0.75 kW to 75 kW, UL Type 1/IP 20, (ATV 21H●●●N4)
- 380...480 V three-phase, 0.75 kW to 75 kW, IP 54, (ATV 21W●●●N4 and ATV 21W●●●N4C)

The Altivar 21 drive integrates the Modbus protocols as standard as well as numerous functions. With the communication cards offered (LONWORKS, METASYS N2, APOGEE FLN and BACnet) the Altivar 21 is the ideal drive for the building market (HVAC).

The entire range conforms to international standards IEC/EN61800-5-1, IEC/EN61800-2, IEC/EN61800-3. It is UL, CSA, C-Tick and NOM 117 certified and has been developed to meet the requirements of directives regarding protection of the environment (RoHS, WEEE, etc.) as well as those of the European Directives to obtain the CE mark.

Electromagnetic compatibility EMC

The incorporation of EMC filters in ATV 21●●●●N4 drives and the recognition of EMC requirements simplifies installation and provides an economical means of ensuring machines meet CE marking requirements.

ATV 21W●●●N4C drives have integrated class B EMC filters, which make them compliant with the requirements of EN 55011 (class B group 1) and IEC/EN 61800-3 (category C1) standards.

ATV 21H●●●M3X drives have been designed without an EMC filter. Filters are available as an option and can be installed by the user to reduce emission levels (see pages 2/56 and 2/57).

Using technology based on a reduced capacitor, the Altivar 21 drive is operational straight away and without disturbance. There is no point adding options to deal with the current harmonics to obtain a THDI (1) of less than 35%. This THDI value is considerably less than the THDI of 48% imposed by the IEC/EN 61000-3-12 standard. The Altivar 21 drive removes the need and the cost of adding a line choke or a DC choke.

Installation

Altivar 21 drives are compact UL Type 1/IP 20 or IP 54 products which meet electromagnetic compatibility requirements and reduce current harmonics.

This range reduces installation costs by optimizing the size of the enclosures (floor-standing, wall-mounted, etc.).

Altivar 21 drives are designed to operate in an enclosure in an ambient temperature of:

- - 40°C without derating
 - Up to 50°C with derating (see curves on pages 2/71 to 2/75)
- They can also be mounted side by side (see page 2/70).

Altivar 21 drives can also be wall-mounted in compliance with UL type 1 requirements using kits VW3 A31 8●● and VW3 A9 ●●● (see page 2/50).

(1) THDI: Total current harmonic distortion

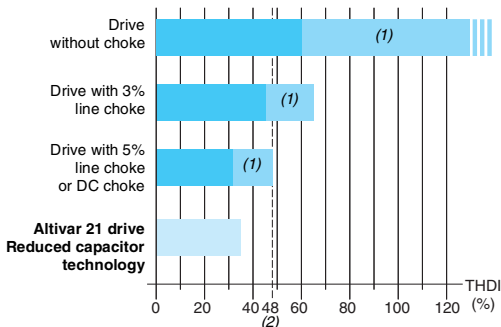

THDI: Total current harmonic distortion

(1) Typical use

(2) Maximum THDI conforming to standard IEC/EN 61000-3-12

Reduced capacitor technology: reduction of current harmonics

2

2.2

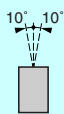
Environmental characteristics		
Conformity to standards		Altivar 21 drives have been developed to conform to the strictest international standards and the recommendations relating to electrical industrial control devices (IEC, EN), in particular: low voltage, IEC/EN 61800-5-1, IEC/EN 61800-3 (conducted and radiated EMC immunity and emissions).
EMC immunity		IEC/EN 61800-3, environments 1 and 2 IEC/EN 61000-4-2 level 3 IEC/EN 61000-4-3 level 3 IEC/EN 61000-4-4 level 4 IEC/EN 61000-4-5 level 3 IEC/EN 61000-4-6 level 3 IEC/EN 61000-4-11 (1)
Conducted and radiated EMC emissions for drives	ATV 21H●●●M3X	IEC/EN 61800-3, environments 1 and 2, category C1, C2 or C3 With additional EMC filter (2): ■ EN 55011 class A group 1, IEC/EN 61800-3 category C2 or C3 ■ EN 55011 class B group 1, IEC/EN 61800-3 category C1
	ATV 21H●●●N4	EN 55011 class A group 1, IEC/EN 61800-3 category C2 or C3 With additional EMC filter (2): ■ EN 55011 class B group 1, IEC/EN 61800-3 category C1
	ATV 21W●●●N4	EN 55011 class A group 1, IEC/EN 61800-3 category C2 or C3
	ATV 21W●●●N4C	EN 55011 class B group 1, IEC/EN 61800-3 category C1
CE marking		The drives have CE marking in accordance with the European directives on low voltage (73/23/EEC and 93/68/EEC) and EMC (89/336/EEC).
Product certifications		UL, CSA, C-Tick and NOM 117
Degree of protection	ATV 21H●●●M3X ATV 21H●●●N4	IEC/EN 61800-5-1, IEC/EN 60529 IP 21 and IP 41 on upper part IP 20 without blanking plate on upper part of cover UL Type 1 with accessories VW3 A31 814...817 and VW3 A9 206...A9 208 (see page 2/50)
	ATV 21W●●●N4 ATV 21W●●●N4C	IP 54
Vibration resistance		1.5 mm peak to peak from 3...13 Hz, 1 gn from 13...200 Hz, conforming to IEC/EN 60068-2-6
Shock resistance		15 gn for 11 ms conforming to IEC/EN 60068-2-27
Maximum ambient pollution	ATV 21H075M3X...HD18M3X ATV 21H075N4...HD18N4 ATV 21W075N4...WD18N4 ATV 21W075N4C...WD18N4C	Degree 2 conforming to IEC/EN 61800-5-1
	ATV 21HD22M3X, HD30M3X ATV 21HD22N4...HD75N4 ATV 21WD22N4...WD75N4 ATV 21WD22N4C...WD75N4C	Degree 3 conforming to IEC/EN 61800-5-1
Environmental conditions	ATV 21H●●●M3X ATV 21●●●N4 ATV 21W●●●N4C	IEC 60721-3-3 classes 3C1 and 3S2
Relative humidity		5...95% without condensation or dripping water conforming to IEC 60068-2-3
Ambient air temperature around the unit	Operation	°C For ATV 21H●●●M3X and ATV 21H●●●N4 drives: -10...+40 without derating. Up to 50°C with derating, see the derating curves on pages 2/71 to 2/75. For ATV 21W●●●N4 and ATV 21W●●●N4C drives: -10...+40 without derating. Up to +50°C with derating, see the derating curves on pages 2/76 and 2/77.
	Storage	°C -25...+70
Maximum operating altitude		m 1000 without derating 1000...3000 derating the current by 1% per additional 100 m. Limited to 2000 m for the "Corner Grounded" distribution network.
Operating position Maximum permanent angle in relation to the normal vertical mounting position		

(1) Drive behaviour according to the drive configurations (see pages 2/92, 2/93, 2/96 and 2/97).
(2) See table on page 2/57 to check permitted cable lengths.

Drive characteristics

Output frequency range		Hz	0.5...200
Configurable switching frequency	ATV 21H075M3X...HD15M3X ATV 21H075N4...HD15N4	kHz	Nominal switching frequency: 12 kHz without derating in continuous operation. Adjustable during operation from 6...16 kHz Above 12 kHz, see the derating curves on pages 2/71 to 2/73.
	ATV 21HD18M3X...HD30M3X ATV 21HD18N4...HD75N4	kHz	Nominal switching frequency: 8 kHz without derating in continuous operation. Adjustable during operation from 6...16 kHz Above 8 kHz, see the derating curves on page 2/72 to 2/75.
	ATV 21W075N4...WD15N4 ATV 21W075N4C...WD15N4C	kHz	Nominal switching frequency: 12 kHz without derating in continuous operation. Adjustable during operation from 6...16 kHz Above 12 kHz, see the derating curves on page 2/76.
	ATV 21WD18N4...WD75N4 ATV 21WD18N4C...WD75N4C	kHz	Nominal switching frequency: 8 kHz without derating in continuous operation. Adjustable during operation from 6...16 kHz Above 8 kHz, see the derating curves on pages 2/76 and 2/77.
Speed range			1...10
Speed accuracy	For a torque variation of 0.2 T _n to T _n		±10% of nominal slip, without speed feedback
Torque accuracy			±15%
Transient overtorque			120% of the nominal motor torque (typical value at ±10%) for 60 s
Maximum transient current			110% of the nominal drive current for 60 s (typical value)
Motor control profile	Asynchronous motor		Energy saving ratio Quadratic voltage/frequency ratio Constant voltage/frequency ratio Constant voltage/frequency ratio with automatic IR compensation Sensorless Flux Vector Control (FVC) (current vector)
	Synchronous motor		Current flux vector control without speed feedback
Frequency loop			PI regulator with adjustable structure for a speed response adapted to the machine (accuracy, speed)
Slip compensation			Automatic whatever the load. Can be suppressed or adjusted Not available with voltage/frequency ratios

Electrical power characteristics

Power supply	Voltage	V	200 - 15%...240 + 10% three-phase for ATV 21H●●●M3X 380 - 15%...480 + 10% three-phase for ATV 21●●●●N4 and ATV 21W●●●N4C	
	Frequency	Hz	50 - 5%...60 + 5%	
Signalling			1 red LED: LED lit indicates the presence of voltage on the drive DC bus	
Output voltage			Maximum three-phase voltage equal to line supply voltage	
Drive noise level	ATV 21H075M3X...HU75M3X ATV 21H075N4...HD11N4	dBA	51	
	ATV 21HD11M3X...HD18M3X ATV 21HD15N4, HD18N4	dBA	54	
	ATV 21HD22M3X ATV 21HD22N4, HD30N4	dBA	59.9	
	ATV 21HD30M3X	dBA	63.7	
	ATV 21HD37N4, HD45N4	dBA	64	
	ATV 21HD55N4, HD75N4	dBA	63.7	
	ATV 21W075N4...WU22N4 ATV 21W075N4C...WU22N4C	dBA	48	
	ATV 21WU30N4...WU75N4 ATV 21WU30N4C...WU75N4C	dBA	55	
	ATV 21WD11N4, WD15N4 ATV 21WD11N4C, WD15N4C	dBA	57.4	
	ATV 21WD18N4 ATV 21WD18N4C	dBA	60.2	
	ATV 21WD22N4, WD30N4 ATV 21WD22N4C, WD30N4C	dBA	59.9	
	ATV 21WD37N4, WD45N4 ATV 21WD37N4C, WD45N4C	dBA	64	
	ATV 21WD55N4, WD75N4 ATV 21WD55N4C, WD75N4C	dBA	63.7	
	Electrical isolation			Between power and control (inputs, outputs, power supplies)

Connection cable characteristics

Type of cable for	Mounting in an enclosure	Single-strand IEC cable, ambient temperature 45°C, copper 90°C XLPE/EPR or copper 70°C PVC
	Mounting in an enclosure with a UL Type 1 kit	3-strand UL 508 cable except for choke (2-strand UL 508 cable), ambient temperature 40°C, copper 75°C PVC

Connection characteristics (terminals for the power supply and the motor)

Drive terminals		L1/R, L2/S, L3/T	U/T1, V/T2, W/T3
Maximum wire size and tightening torque	ATV 21H075M3X...HU22M3X	1.5 mm ² , AWG 14 1.4 Nm	
	ATV 21HU30M3X	2.5 mm ² , AWG 12 1.4 Nm	
	ATV 21HU40M3X	2.5 mm ² , AWG 10 1.4 Nm	
	ATV 21HU55M3X	6 mm ² , AWG 8 2.8 Nm	
	ATV 21HU75M3X	10 mm ² , AWG 8 2.8 Nm	
	ATV 21HD11M3X	16 mm ² , AWG 6 5 Nm	
	ATV 21HD15M3X	25 mm ² , AWG 4 5 Nm	
	ATV 21HD18M3X	35 mm ² , AWG 3 5 Nm	
	ATV 21HD22M3X	35 mm ² , AWG 2 12 Nm	
	ATV 21HD30M3X	70 mm ² , AWG 1/0 41 Nm	
	ATV 21H075N4...HU55N4	2 mm ² , AWG 14 1.4 Nm	
	ATV 21HU75N4	2 mm ² , AWG 12 2.8 Nm	
	ATV 21HD11N4	3.5 mm ² , AWG 10 2.8 Nm	
	ATV 21HD15N4	5.5 mm ² , AWG 8 5 Nm	
	ATV 21HD18N4	8 mm ² , AWG 8 5 Nm	
	ATV 21HD22N4	14 mm ² , AWG 6 12 Nm	
	ATV 21HD30N4	22 mm ² , AWG 4 12 Nm	
	ATV 21HD37N4, HD45N4	50 mm ² , AWG 1/0 24 Nm, 212 lb.in	
	ATV 21HD55N4, HD75N4	150 mm ² , 300 kcmil 41 Nm, 360 lb.in	
	ATV 21W075N4...WU55N4	1.5 mm ² , AWG 14	
	ATV 21W075N4C...WU55N4C	1.4 Nm	
	ATV 21WU75N4	2.5 mm ² , AWG 12	
	ATV 21WU75N4C	2.8 Nm	
	ATV 21WD11N4	4 mm ² , AWG 10	
	ATV 21WD11N4C	4 Nm	
	ATV 21WD15N4	6 mm ² , AWG 8	
	ATV 21WD15N4C	4 Nm	
	ATV 21WD18N4	10 mm ² , AWG 8	
	ATV 21WD18N4C	4 Nm	
	ATV 21WD22N4	16 mm ² , AWG 6	
	ATV 21WD22N4C	12 Nm	
	ATV 21WD30N4	25 mm ² , AWG 4	
	ATV 21WD30N4C	41 Nm	
	ATV 21WD37N4, WD45N4	50 mm ² , AWG 1/0	50 mm ² , AWG 1/0
	ATV 21WD37N4C, WD45N4C	8 Nm, 70.8 lb.in	24 Nm, 212 lb.in
	ATV 21WD55N4, WD75N4	150 mm ² , 250 kcmil	150 mm ² , 300 kcmil
	ATV 21WD55N4C, WD75N4C	20 Nm, 177 lb.in	41 Nm, 360 lb.in

2

2.2

Electrical control characteristics

Internal supplies available		<p>Short-circuit and overload protection:</p> <ul style="list-style-type: none"> ■ 1 x 10.5 V \pm5% supply for the reference potentiometer (1 to 10 kΩ), maximum current 10 mA ■ 1 x 24 V \pm supply (min. 21 V, max. 27 V), maximum current 200 mA
Analog inputs	VIA	<p>Switch-configurable current or voltage analog input:</p> <ul style="list-style-type: none"> ■ Voltage analog input 0...10 V \pm, impedance 30 kΩ (max. safe voltage 24 V) ■ Current analog input X-Y mA by programming X and Y from 0 to 20 mA, with impedance 242 Ω <p>Max. sampling time: 2 ms \pm0.5 ms Resolution: 11 bits Accuracy: \pm0.6% for a temperature variation of 60°C Linearity: \pm0.15% of the maximum value This analog input is also configurable as a logic input (see page 2/63).</p>
	VIB	<p>Voltage analog input, configurable as an analog input or as a PTC probe input.</p> <p>Voltage analog input:</p> <ul style="list-style-type: none"> ■ 0...10 V \pm, impedance 30 kΩ (max. safe voltage 24 V) ■ Max. sampling time: 2 ms \pm0.5 ms ■ Resolution: 11 bits ■ Accuracy: \pm0.6% for a temperature variation of 60°C ■ Linearity: \pm0.15% of the maximum value <p>PTC probe input:</p> <ul style="list-style-type: none"> ■ 6 probes max. mounted in series ■ Nominal value < 1.5 kΩ ■ Trip resistance 3 kΩ, reset value 1.8 kΩ ■ Short-circuit protection < 50 Ω
Analog output	FM	<p>1 switch-configurable voltage or current analog output:</p> <ul style="list-style-type: none"> ■ Voltage analog output 0...10 V \pm, minimum load impedance 470 Ω ■ Current analog output X-Y mA by programming X and Y from 0 to 20 mA, maximum load impedance 500 Ω <p>Max. sampling time: 2 ms \pm0.5 ms Resolution: 10 bits Accuracy: \pm1% for a temperature variation of 60°C Linearity: \pm0.2%</p>
Configurable relay outputs	FLA, FLB, FLC	<p>1 relay logic output, one "N/C" contact and one "N/O" contact with common point</p> <p>Minimum switching capacity: 3 mA for 24 V \pm</p> <p>Maximum switching capacity:</p> <ul style="list-style-type: none"> ■ On resistive load ($\cos \varphi = 1$): 5 A for 250 V \sim or 30 V \pm ■ On inductive load ($\cos \varphi = 0.4$ and L/R = 7 ms): 2 A for 250 V \sim or 30 V \pm <p>Max. response time: 7 ms \pm0.5 ms Electrical service life: 100,000 operations</p>
	RY, RC	<p>1 relay logic output, one "N/O" contact</p> <p>Minimum switching capacity: 3 mA for 24 V \pm</p> <p>Maximum switching capacity:</p> <ul style="list-style-type: none"> ■ On resistive load ($\cos \varphi = 1$): 5 A for 250 V \sim or 30 V \pm ■ On inductive load ($\cos \varphi = 0.4$ and L/R = 7 ms): 2 A for 250 V \sim or 30 V \pm <p>Max. response time: 7 ms \pm0.5 ms Electrical service life: 100,000 operations</p>
Logic inputs	F, R, RES	<p>3 programmable logic inputs, 24 V \pm, compatible with level 1 PLC, IEC 65A-68 standard</p> <p>Impedance: 3.5 kΩ Maximum voltage: 30 V Max. sampling time: 2 ms \pm0.5 ms Multiple assignment makes it possible to configure several functions on one input</p>
	Positive logic (Source)	State 0 if \leq 5 V or logic input not wired, state 1 if \geq 11 V
	Negative logic (Sink)	State 0 if \geq 16 V or logic input not wired, state 1 if \leq 10 V
Maximum I/O wire size and tightening torque		<p>2.5 mm² (AWG 14) 0.6 Nm</p>

2

2.2

Electrical control characteristics (continued)			
Acceleration and deceleration ramps			Ramp profiles: <ul style="list-style-type: none"> ■ Linear, can be adjusted separately from 0.01 to 3200 s ■ Automatic adaptation of acceleration and deceleration ramp times based on the load.
Braking to a standstill			By DC injection by a command on a programmable logic input. Period adjustable from 0 to 20s or continuous, current adjustable from 0 to I_n , frequency threshold adjustable from 0 to the maximum frequency.
Main drive protection and safety features			Thermal protection: <ul style="list-style-type: none"> ■ Against overheating ■ Of the power stage Protection against: <ul style="list-style-type: none"> ■ Short-circuits between motor phases ■ Input phase breaks ■ Overcurrents between output phases and earth ■ Overvoltages on the DC bus ■ A break on the control circuit ■ Exceeding the limit speed Safety function for: <ul style="list-style-type: none"> ■ Line supply overvoltage and undervoltage ■ Input phase loss
Motor protection (see page 2/95)			Thermal protection integrated in drive via continuous calculation of I^2t taking speed into account: <ul style="list-style-type: none"> ■ Memorization of the motor thermal state ■ Function can be modified via operator dialogue terminals, depending on the type of motor (force-cooled or self-cooled) Protection against motor phase breaks Protection with PTC probes
Dielectric strength	ATV 21H●●●M3X		Between earth and power terminals: 2830 V --- Between control and power terminals: 4230 V ---
	ATV 21●●●●N4 ATV 21W●●●N4C		Between earth and power terminals: 3535 V --- Between control and power terminals: 5092 V ---
Insulation resistance to earth			> 1 MΩ (electrical isolation) 500 V --- for 1 minute
Frequency resolution	Display units	Hz	0.1
	Analog inputs	Hz	0.024/50 Hz (11 bits)

Communication port characteristics

Protocol		Modbus
Structure	Connector	1 RJ45 connector
	Physical interface	2-wire RS 485
	Transmission mode	RTU
	Transmission speed	Configurable via the display terminal: 9600 bps or 19200 bps
	Format	Configurable via the terminal: - 8 bits, odd parity, 1 stop - 8 bits, even parity, 1 stop - 8 bits, no parity, 1 stop
	Polarization	No polarization impedances These should be provided by the wiring system (for example, in the master)
	Address	1 to 247, configurable via the display terminal
Services	Messaging	Read Holding Registers (03) 2 words maximum Write Single Register (06) Write Multiple Registers (16) 2 words maximum Read Device Identification (43)
	Communication monitoring	Can be inhibited. "Time out", which can be set between 0.1 s and 100 s

Variable speed drives for asynchronous motors

Altivar 21 Reduction of current harmonics

2

2.2

Presentation

The traditional solutions for reducing current harmonics are as follows:

- Line chokes
- DC chokes

These solutions typically reduce the THDI (1) to a level less than 48% (2). If a choke is not added, the THDI is generally between 60 and 130% (see diagram opposite).

Depending on their type, these external or internal chokes are most often offered as an option and have the following disadvantages:

- Increased cost
- Increased installation time
- Increased overall size
- Increased drive losses with a DC choke

In order to overcome these disadvantages, the Altivar 21 drive integrates new technology: **reduced capacitor technology**.

This integrated technology makes it possible to obtain a THDI (1) less than 35% without having to add a choke, offering the following advantages:

- Optimized technology through the reduction of current harmonics by decreasing the filter capacitors
- Greater reduction of current harmonics compared with traditional solutions, line chokes and DC chokes
- Quick setup
- Reduced costs

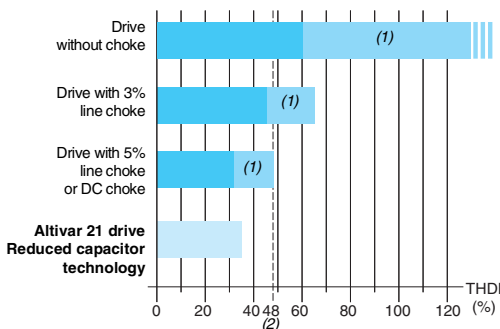

THDI: Total current harmonic distortion
(1) Typical use
(2) Maximum THDI conforming to standard IEC/EN 61000-3-12

THDI based on the technologies used

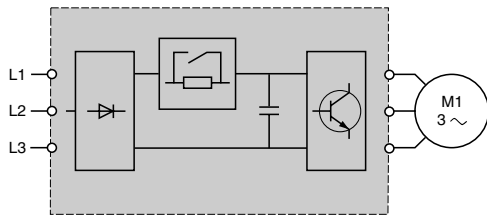

Altivar 21

Reduced capacitor technology

Example of current harmonic levels for ATV 21H●●●M3X drives (3)

Motor power kW HP	For ATV 21 drives	Line supply		Current harmonic levels																THD (4)		
		Line current A	Line Isc kA	H1 A	H5 %	H7 %	H11 %	H13 %	H17 %	H19 %	H23 %	H25 %	H29 %	H31 %	H35 %	H37 %	H41 %	H43 %	H47 %		H49 %	
Three-phase supply voltage: 230 V 50 Hz																						
0.75	1	H075M3X	2.83	5	2.7	17.8	17.9	8.9	9.6	5.8	6.6	4.3	5.1	3.4	4.2	2.8	3.6	2.3	3.2	2	2.9	31.3
1.5	2	HU15M3X	5.29	5	5.03	17.7	18.2	8.7	9.8	5.7	6.9	4.1	5.4	3.3	4.5	2.7	4	2.4	3.7	2.3	3.7	31.6
2.2	3	HU22M3X	7.56	5	7.2	17.1	18	8.5	9.6	5.5	6.7	4	5.2	3.1	4.3	2.5	3.7	2.1	3.4	2	3.3	30.7
3	-	HU30M3X	10.31	5	9.68	17.6	18.6	8.5	10	5.4	7.3	4	5.9	3.4	5.3	3.9	5.8	9.3	12.2	7.8	1	32.4
4	5	HU40M3X	13.45	5	12.73	16.9	18.3	8.2	9.9	5.2	6.9	3.7	5.4	3	4.7	3.2	4.7	7.4	10	6.1	0.8	31.1
5.5	7.5	HU55M3X	18.09	22	17.27	17.1	17.8	8.7	9.5	5.7	6.5	4.1	5	3.2	4.1	2.6	3.5	2.2	3.1	1.9	2.8	30.7
7.5	10	HU75M3X	24.36	22	23.22	17.1	18	8.6	9.6	5.6	6.7	4.1	5.2	3.2	4.3	2.6	3.7	2.3	3.3	2.1	3.2	30.8
11	15	HD11M3X	35.7	22	33.4	18	19	8.6	10	5.6	7.9	4.3	6.9	4.3	7.2	7.1	11.3	11.3	4.3	3.8	0.6	35.5
15	20	HD15M3X	47.6	22	44.92	16.9	18.6	8.1	10	5.1	7.5	3.7	6.3	3.3	6.2	5.3	9.9	9.9	3	2.9	0.8	33.3
18.5	25	HD18M3X	57.98	22	54.96	16.5	18.4	7.9	10	4.9	7.1	3.4	5.8	2.7	5.5	4	8.9	9	3	2.3	1.4	32
22	30	HD22M3X	69.01	22	65.08	16.3	18.8	7.6	10	4.6	7.8	3.2	7.1	3.8	11.2	12.2	4.9	2.7	1.8	1.5	1.3	35
30	40	HD30M3X	93.03	22	88.51	16	18.3	7.5	9.9	4.4	6.9	2.9	5.8	2.9	8.3	8.9	4.8	1.9	2.3	1.1	1.6	32.1

(1) Total current harmonic distortion.
(2) Maximum total conforming to standard IEC/EN 61000-3-12.
(3) Example of current harmonic levels up to harmonic order 49 for a 230 V 50 Hz supply with reduced capacitor technology.
(4) Total harmonic distortion conforming to standard IEC/EN 61000-3-12.

Variable speed drives for asynchronous motors

Altivar 21

Reduction of current harmonics

Example of current harmonic levels for ATV 21H●●●N4 drives (1)

Motor power	For ATV 21 drives	Line supply		Current harmonic levels																THD (2)		
		Line current	Line Isc	H1	H5	H7	H11	H13	H17	H19	H23	H25	H29	H31	H35	H37	H41	H43	H47		H49	
kW	HP	A	kA	A	%	%	%	%	%	%	%	%	%	%	%	%	%	%	%	%	%	
Three-phase supply voltage: 400 V 50 Hz																						
0.75	1	H075N4	1.64	5	1.55	19.2	18.3	9.4	9.9	6.1	6.8	4.5	5.3	3.6	4.4	3	3.8	2.6	3.4	2.3	3.1	32.8
1.5	2	HU15N4	3.03	5	2.89	17.5	17.8	8.8	9.5	5.8	6.5	4.3	5	3.4	4.1	2.8	3.5	2.3	3	2	2.7	30.9
2.2	3	HU22N4	4.33	5	4.14	17.2	17.7	8.7	9.4	5.7	6.4	4.2	4.9	3.3	4	2.7	3.3	2.2	2.9	1.9	2.6	30.5
3	-	HU30N4	5.83	5	5.56	17.4	18.1	8.6	9.7	5.6	6.8	4.1	5.3	3.2	4.4	2.6	3.8	2.3	3.5	2.1	3.4	31.2
4	5	HU40N4	7.66	5	7.3	17	17.9	8.5	9.6	5.5	6.6	4	5.1	3.1	4.2	2.5	3.6	2.1	3.3	1.9	3.1	30.6
5.5	7.5	HU55N4	10.4	22	9.93	17.2	17.6	8.8	9.3	5.8	6.3	4.3	4.8	3.4	3.9	2.8	3.3	2.3	2.8	2	2.5	30.5
7.5	10	HU75N4	13.98	22	13.34	17.3	17.9	8.7	9.5	5.7	6.5	4.2	5	3.3	4.1	2.7	3.5	2.3	3.1	2	2.8	30.9
11	15	HD11N4	20.13	22	19.23	17	17.7	8.7	9.4	5.7	6.4	4.2	4.9	3.2	4	2.6	3.3	2.2	2.9	1.9	2.6	30.4
15	20	HD15N4	27.14	22	25.83	17.1	18.1	8.5	9.7	5.5	6.8	4	5.3	3.1	4.4	2.6	3.9	2.3	3.6	2.4	3.6	30.9
18.5	25	HD18N4	33.17	22	31.61	16.8	18	8.4	9.6	5.5	6.7	3.9	5.1	3	4.2	2.5	3.7	2.2	3.4	2.2	3.4	30.5
22	30	HD22N4	39.38	22	37.45	16.8	18.1	8.3	9.8	5.3	6.8	3.8	5.3	2.9	4.5	2.5	4.1	2.6	4.2	4.2	5.7	30.7
30	40	HD30N4	53.18	22	50.7	16.6	17.9	8.2	9.6	5.2	6.5	3.7	5	2.8	4	2.2	3.5	2.1	3.4	3.3	5.3	30
37	50	HD37N4	65.57	22	62.24	16.5	18.1	8.1	9.7	5.1	6.6	3.6	5.1	2.8	4.2	3	4.2	8.5	9.5	4.2	0.9	30.3
45	60	HD45N4	79.97	22	76.14	16.3	18.1	8.1	9.7	5.1	6.6	3.6	5.1	2.8	4.3	2.9	4.3	7.5	6.9	3.5	0.5	30.2
55	75	HD55N4	99.3	22	94.36	16	18.9	7.8	10	5.2	8.1	5	7.7	8.7	4.8	4	0.2	1.9	0.9	1.2	0.9	32.7
75	100	HD75N4	137.3	22	131.07	15.4	18.9	7.5	10	4.9	7.6	4.4	6.7	7.3	3	3.1	0.6	1.5	0.9	0.9	0.8	31.1

Example of current harmonic levels for ATV 21W●●●N4 and W●●●N4C drives (1)

Three-phase supply voltage: 400 V 50 Hz

Motor power	For ATV 21 drives	Line supply		Current harmonic levels																THD (2)		
		Line current	Line Isc	H1	H5	H7	H11	H13	H17	H19	H23	H25	H29	H31	H35	H37	H41	H43	H47		H49	
kW	HP	A	kA	A	%	%	%	%	%	%	%	%	%	%	%	%	%	%	%	%	%	
0.75	1	W075N4 W075N4C	1.64	5	1.55	19.2	18.3	9.4	9.9	6.1	6.8	4.5	5.3	3.6	4.4	3.0	3.8	2.6	3.4	2.3	3.1	32.8
1.5	2	WU15N4 WU15N4C	3.03	5	2.89	17.5	17.8	8.8	9.5	5.8	6.5	4.3	5.0	3.4	4.1	2.8	3.5	2.3	3.0	2.0	2.7	30.9
2.2	3	WU22N4 WU22N4C	4.33	5	4.14	17.2	17.7	8.7	9.4	5.7	6.4	4.2	4.9	3.3	4.0	2.7	3.3	2.2	2.9	1.9	2.6	30.5
3	-	WU30N4 WU30N4C	5.83	5	5.56	17.4	18.1	8.6	9.7	5.6	6.8	4.1	5.3	3.2	4.4	2.6	3.8	2.3	3.5	2.1	3.4	31.2
4	5	WU40N4 WU40N4C	7.66	5	7.30	17.0	17.9	8.5	9.6	5.5	6.6	4.0	5.1	3.1	4.2	2.5	3.6	2.1	3.3	1.9	3.1	30.6
5.5	7.5	WU55N4 WU55N4C	10.40	22	9.93	17.2	17.6	8.8	9.3	5.8	6.3	4.3	4.8	3.4	3.9	2.8	3.3	2.3	2.8	2.0	2.5	30.5
7.5	10	WU75N4 WU75N4C	13.98	22	13.34	17.3	17.9	8.7	9.5	5.7	6.5	4.2	5.0	3.3	4.1	2.7	3.5	2.3	3.1	2.0	2.8	30.9
11	15	WD11N4 WD11N4C	20.17	22	19.23	17.2	18.0	8.6	9.6	5.6	6.7	4.1	5.2	3.2	4.3	2.6	3.7	2.3	3.3	2.1	3.1	30.9
15	20	WD15N4 WD15N4C	27.07	22	25.85	16.9	17.8	8.5	9.5	5.6	6.5	4.0	5.0	3.1	4.1	2.5	3.5	2.1	3.1	1.9	2.8	30.4
18.5	25	WD18N4 WD18N4C	33.22	22	31.62	16.9	18.0	8.4	9.7	5.4	6.7	3.9	5.2	3.0	4.4	2.5	3.8	2.3	3.6	2.6	3.8	30.7
22	30	WD22N4 WD22N4C	39.38	22	37.45	16.8	18.1	8.3	9.8	5.3	6.8	3.8	5.3	2.9	4.5	2.5	4.1	2.6	4.2	4.2	5.7	30.7
30	40	WD30N4 WD30N4C	53.18	22	50.70	16.6	17.9	8.2	9.6	5.2	6.5	3.7	5.0	2.8	4.0	2.2	3.5	2.1	3.4	3.3	5.3	30.0
37	50	WD37N4 WD37N4C	65.57	22	62.24	16.5	18.1	8.1	9.7	5.1	6.6	3.6	5.1	2.8	4.2	3.0	4.2	8.5	9.5	4.2	0.9	30.3
45	60	WD45N4 WD45N4C	79.97	22	76.14	16.3	18.1	8.1	9.7	5.1	6.6	3.6	5.1	2.8	4.3	2.9	4.3	7.5	6.9	3.5	0.5	30.2
55	75	WD55N4 WD55N4C	99.30	22	94.36	16.0	18.9	7.8	10.0	5.2	8.1	5.0	7.7	8.7	4.8	4.0	0.2	1.9	0.9	1.2	0.9	32.7
75	100	WD75N4 WD75N4C	137.30	22	131.07	15.4	18.9	7.5	10.0	4.9	7.6	4.4	6.7	7.3	3.0	3.1	0.6	1.5	0.9	0.9	0.8	31.1

(1) Example of current harmonic levels up to harmonic order 49 for a 400 V 50 Hz supply with reduced capacitor technology.

(2) Total harmonic distortion conforming to standard IEC/EN 61000-3-12.

Variable speed drives for asynchronous motors

Altivar 21

2

2.2

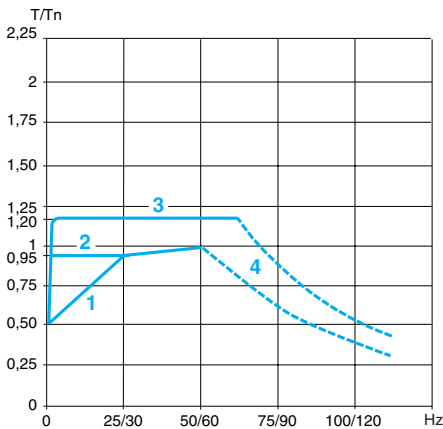

Open loop applications

Torque characteristics (typical curves)

The curves below define the available continuous torque and transient overtorque for both force-cooled and self-cooled motors. The only difference is in the ability of the motor to provide a high continuous torque at less than half the nominal speed.

Open loop applications

- 1 Self-cooled motor: continuous useful torque (1)
- 2 Force-cooled motor: continuous useful torque
- 3 Overtorque for 60 seconds maximum
- 4 Torque in overspeed at constant power (2)

Motor thermal protection

Altivar 21 drives feature thermal protection designed specifically for self-cooled or forced-cooled variable speed motors.

This motor thermal protection is designed for a maximum ambient temperature of 40°C around the motor. If the temperature around the motor exceeds 40°C, thermal protection should be provided directly by thermistor probes (PTC) integrated in the motor. The probes are managed directly by the drive.

(1) For power ratings ≤ 250 W, motor derating is 20% instead of 50% at very low frequencies.

(2) The motor nominal frequency and the maximum output frequency can be adjusted from 10 to 200 Hz.

Check the mechanical overspeed characteristics of the selected motor with the manufacturer.

Special uses

Using Altivar 21 drives with synchronous motors

Altivar 21 drives are also suitable for powering synchronous motors (sinusoidal electromotive force) in open loop mode and are used to achieve performance levels comparable to those associated with an asynchronous motor in sensorless flux vector control.

This drive/motor combination makes it possible to obtain remarkable speed accuracy and maximum torque even at zero speed. The design and construction of synchronous motors are such that they offer enhanced power density and high-speed performance in a compact unit. Drive control for synchronous motors does not cause stalling.

Connecting motors in parallel

One of the following motor control ratios must be used in order to connect motors in parallel:

- Quadratic voltage/frequency ratio
- Constant voltage/frequency ratio
- Constant voltage/frequency ratio with automatic IR compensation

The nominal current of the drive must be greater than or equal to the sum of the currents of the motors to be controlled.

In this case, provide external thermal protection for each motor using probe or thermal overload relays. For cable runs over a certain length, taking account of all the tap links, it is advisable either to install an output filter between the drive and the motors.

If several motors are used in parallel, there are two possible scenarios:

- The motors have equal power ratings, in which case the torque characteristics will remain optimized after the drive has been configured
- The motors have different power ratings, in which case the torque characteristics will not be optimized for all the motors

Switching the motor at the drive output

The drive can be switched when locked or unlocked. If the drive is switched on-the-fly (drive unlocked), the motor is controlled and accelerates until it reaches the reference speed smoothly following the acceleration ramp. This use requires configuration of the automatic catching a spinning load ("catch on the fly") and the motor phase loss on output cut functions.

Typical applications:

- Loss of safety circuit at drive output
- Bypass function
- Switching of motors connected in parallel

Test on a low power motor or without a motor

In a testing or maintenance environment the drive can be checked without having to switch to a motor with the same rating as the drive (particularly useful in the case of high power drives). This use requires deactivation of motor phase loss function.

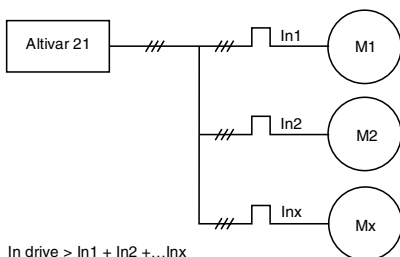

$I_n \text{ drive} > I_{n1} + I_{n2} + \dots + I_{nx}$
Connecting motors in parallel

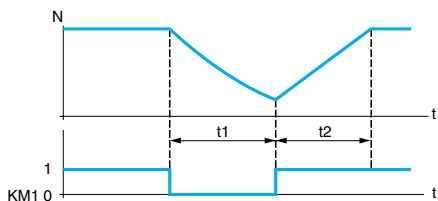
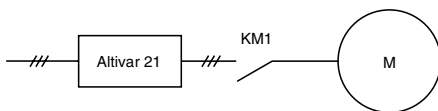

KM1: Output contactor
t1: Deceleration without ramp (freewheel)
t2: Acceleration with ramp
N: Speed

Example of loss of output contactor

Variable speed drives for asynchronous motors

Altivar 21

UL Type 1/IP 20 drives



ATV 21H075M3X

2



ATV 21HU75N4

2.2



ATV 21HD75N4

UL Type 1/IP 20 drives without EMC filter

Motor		Line supply				Altivar 21		Reference	Weight	
Power indicated on plate (1)	kW	HP	Line current (2)		Apparent power	Maximum prospective line Isc	Max. continuous current (1)			Max. transient current for 60 s
			200 V	240 V				240 V	230 V	
			A	A	kVA	kA	A	A	kg	
Three phase supply voltage: 200...240 V 50/60 Hz										
0.75	1	3.3	2.7	1.8	5	5	4.6	5.1	ATV 21H075M3X	1.800
1.5	2	6.1	5.1	2.9	5	5	7.5	8.3	ATV 21HU15M3X	1.800
2.2	3	8.7	7.3	4.0	5	5	10.6	11.7	ATV 21HU22M3X	1.800
3	–	11.9	10.0	5.2	5	5	13.7	15.1	ATV 21HU30M3X	3.050
4	5	15.7	13.0	6.7	5	5	17.5	19.3	ATV 21HU40M3X	3.050
5.5	7.5	20.8	17.3	9.2	22	22	24.2	26.6	ATV 21HU55M3X	6.100
7.5	10	27.9	23.3	12.2	22	22	32.0	35.2	ATV 21HU75M3X	6.100
11	15	42.1	34.4	17.6	22	22	46.2	50.8	ATV 21HD11M3X	11.550
15	20	56.1	45.5	23.2	22	22	61	67.1	ATV 21HD15M3X	11.550
18.5	25	67.3	55.8	28.5	22	22	74.8	82.3	ATV 21HD18M3X	11.550
22	30	80.4	66.4	33.5	22	22	88	96.8	ATV 21HD22M3X	27.400
30	40	113.3	89.5	44.6	22	22	117	128.7	ATV 21HD30M3X	38.650

IP 20/UL Type 1 drives with an integrated class A EMC filter

Motor		Line supply				Altivar 21		Reference	Weight	
Power indicated on plate (1)	kW	HP	Line current (2)		Apparent power	Maximum prospective line Isc	Max. continuous current (1)			Max. transient current for 60 s
			380 V	480 V				380 V	380 V/460 V	
			A	A	kVA	kA	A	A	kg	
Three phase supply voltage: 380...480 V 50/60 Hz										
0.75	1	1.7	1.4	1.6	5	5	2.2	2.4	ATV 21H075N4	2.000
1.5	2	3.2	2.5	2.8	5	5	3.7	4	ATV 21HU15N4	2.000
2.2	3	4.6	3.6	3.9	5	5	5.1	5.6	ATV 21HU22N4	2.000
3	–	6.2	4.9	5.5	5	5	7.2	7.9	ATV 21HU30N4	3.350
4	5	8.1	6.4	6.9	5	5	9.1	10	ATV 21HU40N4	3.350
5.5	7.5	10.9	8.6	9.1	22	22	12	13.2	ATV 21HU55N4	3.350
7.5	10	14.7	11.7	12.2	22	22	16	17.6	ATV 21HU75N4	6.450
11	15	21.1	16.8	17.1	22	22	22.5	24.8	ATV 21HD11N4	6.450
15	20	28.5	22.8	23.2	22	22	30.5	33.6	ATV 21HD15N4	11.650
18.5	25	34.8	27.8	28.2	22	22	37	40.7	ATV 21HD18N4	11.650
22	30	41.6	33.1	33.2	22	22	43.5	47.9	ATV 21HD22N4	26.400
30	40	56.7	44.7	44.6	22	22	58.5	64.4	ATV 21HD30N4	26.400
37	50	68.9	54.4	52	22	22	79	86.9	ATV 21HD37N4	38.100
45	60	83.8	65.9	61.9	22	22	94	103.4	ATV 21HD45N4	38.100
55	75	102.7	89	76.3	22	22	116	127.6	ATV 21HD55N4	55.400
75	100	141.8	111.3	105.3	22	22	160	176	ATV 21HD75N4	55.400

(1) These values are given for a nominal frequency switching of 12 kHz up to ATV 21HD15M3X and up to ATV 21HD15N4 or 8 kHz for ATV 21HD18M3X...HD30M3X and ATV 21HD18N4...HD75N4 drives for use in continuous operation.

The switching frequency is adjustable from 6...16 kHz for all ratings.

Above 8 or 12 kHz, depending on the rating, the drive reduces the switching frequency itself in the event of an excessive temperature rise. For continuous operation above the nominal switching frequency, derate the nominal drive current (see derating curves on pages 2/71 to 2/75).

(2) Typical value for the indicated motor power and for the maximum prospective line Isc.

Variable speed drives for asynchronous motors

Altivar 21 IP 54 drives



ATV 21W075N4

IP 54 drives with an integrated class A EMC filter

Motor Power indicated on plate (1)	Line supply				Altivar 21		Reference	Weight	
	Line current (2)		Apparent power 380 V	Maximum prospective line Isc	Max. continuous current (1)	Max. transient current for 60 s			
	380 V	480 V							380 V/460 V
kW	HP	A	A	kVA	kA	A	A	kg	
Three phase supply voltage: 380...480 V 50/60 Hz									
0.75	1	1.7	1.4	1.6	5	2.2	2.4	ATV 21W075N4	7.000
1.5	2	3.2	2.5	2.8	5	3.7	4	ATV 21WU15N4	7.000
2.2	3	4.6	3.6	3.9	5	5.1	5.6	ATV 21WU22N4	7.000
3	–	6.2	4.9	5.5	5	7.2	7.9	ATV 21WU30N4	9.650
4	5	8.1	6.4	6.9	5	9.1	10	ATV 21WU40N4	9.650
5.5	7.5	10.9	8.6	9.1	22	12	13.2	ATV 21WU55N4	9.650
7.5	10	14.7	11.7	12.2	22	16	17.6	ATV 21WU75N4	10.950
11	15	21.2	16.9	17.1	22	22.5	24.8	ATV 21WD11N4	30.300
15	20	28.4	22.6	23.2	22	30.5	33.6	ATV 21WD15N4	30.300
18.5	25	34.9	27.8	28.2	22	37	40.7	ATV 21WD18N4	37.400
22	30	41.6	33.1	33.2	22	43.5	47.9	ATV 21WD22N4	49.500
30	40	56.7	44.7	44.6	22	58.5	64.4	ATV 21WD30N4	49.500
37	50	68.9	54.4	52	22	79	86.9	ATV 21WD37N4	57.400
45	60	83.8	65.9	61.9	22	94	103.4	ATV 21WD45N4	57.400
55	75	102.7	89	76.3	22	116	127.6	ATV 21WD55N4	61.900
75	100	141.8	111.3	105.3	22	160	176	ATV 21WD75N4	61.900

IP 54 drives with an integrated class B EMC filter

Motor Power indicated on plate (1)	Line supply				Altivar 21		Reference	Weight	
	Line current (2)		Apparent power 380 V	Maximum prospective line Isc	Max. continuous current (1)	Max. transient current for 60 s			
	380 V	480 V							380 V/460 V
kW	HP	A	A	kVA	kA	A	A	kg	
Three phase supply voltage: 380...480 V 50/60 Hz									
0.75	1	1.7	1.4	1.6	5	2.2	2.4	ATV 21W075N4C	7.500
1.5	2	3.2	2.6	2.8	5	3.7	4	ATV 21WU15N4C	7.500
2.2	3	4.6	3.7	3.9	5	5.1	5.6	ATV 21WU22N4C	7.500
3	–	6.2	5	5.5	5	7.2	7.9	ATV 21WU30N4C	10.550
4	5	8.2	6.5	6.9	5	9.1	10	ATV 21WU40N4C	10.550
5.5	7.5	11	8.7	9.1	22	12	13.2	ATV 21WU55N4C	10.550
7.5	10	14.7	11.7	12.2	22	16	17.6	ATV 21WU75N4C	11.850
11	15	21.1	16.7	17.1	22	22.5	24.8	ATV 21WD11N4C	36.500
15	20	28.4	22.8	23.2	22	30.5	33.6	ATV 21WD15N4C	36.500
18.5	25	34.5	27.6	23.2	22	37	40.7	ATV 21WD18N4C	45.000
22	30	41.1	33.1	33.2	22	43.5	47.9	ATV 21WD22N4C	58.500
30	40	58.2	44.4	44.6	22	58.5	64.4	ATV 21WD30N4C	58.500
37	50	68.9	54.4	52	22	79	86.9	ATV 21WD37N4C	77.400
45	60	83.8	65.9	61.9	22	94	103.4	ATV 21WD45N4C	77.400
55	75	102.7	89	76.3	22	116	127.6	ATV 21WD55N4C	88.400
75	100	141.8	111.3	105.3	22	160	176	ATV 21WD75N4C	88.400

(1) These values are given for a nominal frequency switching of 12 kHz up to ATV 21WD15N4 and up to ATV 21WD15N4C or 8 kHz for ATV 21WD18N4...WD75N4 and ATV 21WD18N4C...WD75N4C drives for use in continuous operation. The switching frequency is adjustable from 6...16 kHz for all ratings.

Above 8 or 12 kHz, depending on the rating, the drive reduces the switching frequency itself in the event of an excessive temperature rise. For continuous operation above the nominal switching frequency, derate the nominal drive current (see derating curves on pages 2/76 to 2/77).

(2) Typical value for the indicated motor power and for the maximum prospective line Isc.



ATV 21WD18N4C

Variable speed drives for asynchronous motors

Altivar 21

Option: dialogue accessories

2

2.2

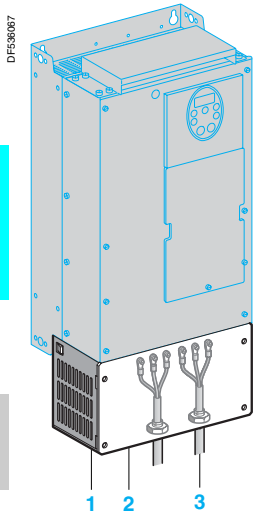

UL Type 1 conformity kit

Kit for UL Type 1 conformity (mounting outside the enclosure)

When the drive is mounted directly on a wall outside the enclosure, this kit can be used to ensure UL Type 1 conformity when connecting the cables with a tube. The shielding is connected inside the kit.

The kit consists of:

- All the mechanical parts 1 including a pre-cut plate 2 for connecting the tubes 3
- Fixing accessories
- A manual

References

For drives	Reference	Weight kg
ATV 21H075M3X...HU22M3X ATV 21H075N4...HU22N4	VW3 A31 814	0.500
ATV 21HU30M3X, HU40M3X ATV 21HU30N4...HU55N4	VW3 A31 815	0.500
ATV 21HU55M3X, HU75M3X ATV 21HU75N4, HD11N4	VW3 A31 816	0.900
ATV 21HD11M3X...HD18M3X ATV 21HD15N4, HD18N4	VW3 A31 817	1.200
ATV 21HD22M3X ATV 21HD22N4, HD30N4	VW3 A9 206	4.000
ATV 21HD37N4, HD45N4	VW3 A9 207	5.000
ATV 21HD30M3X ATV 21HD55N4, HD75N4	VW3 A9 208	7.000

Kit for mounting on U rail

This kit allows easy installation of the ATV 21H075M3X...HU22M3X and ATV 21H075N4...HU22N4 drives by mounting them directly on a 35 mm wide U rail.

Reference

For drives	Reference	Weight kg
ATV 21H075M3X...HU22M3X ATV 21H075N4...HU22N4	VW3 A31 852	0.350

PCSoft software workshop

This PC software workshop is a user-friendly tool for setting up Altivar 21 drives.

It includes different functions such as:

- Configuration preparation
- Setup
- Maintenance

It can be downloaded free of charge from the Internet at "www.telemecanique.com".

It operates in the following PC environments and configurations:

- Microsoft Windows® 98, Microsoft Windows® 2000, Microsoft Windows® XP
- Pentium® 233 MHz or higher, hard disk with 10 MB available, 32 MB RAM
- 256 colour, 640 x 480 pixels or higher definition monitor

Connection

The PCSoft software workshop must be connected directly to the Modbus port on the drive using the PC serial port connection kit.

Note: It is not possible to use the PCSoft software workshop and a communication option card simultaneously. To be able to use the PCSoft software workshop when the drive is equipped with a communication card, the network or communication bus must be deactivated.

Reference

Description	Composition	Reference	Weight kg
PC serial port connection kit	<ul style="list-style-type: none"> ■ 1 x 3 m cable with 2 RJ45 connectors ■ 1 RS 232/RS 485 converter with one 9-way female SUB-D connector and 1 RJ45 connector 	VW3 A8 106	0.350

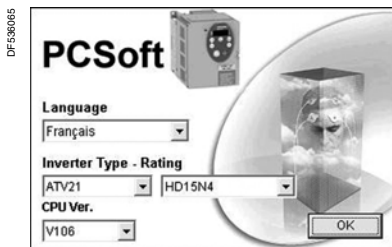

PCSoft software workshop

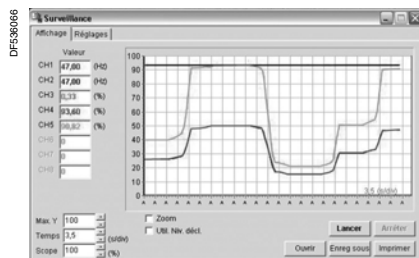

PCSoft software workshop "Monitoring" function

Variable speed drives for asynchronous motors

Altivar 21

Option: dialogue

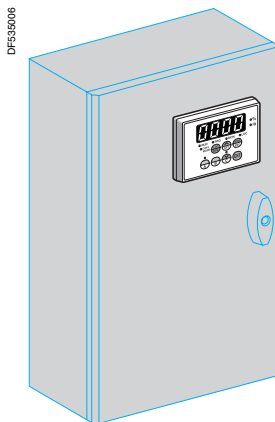

Terminal on enclosure door

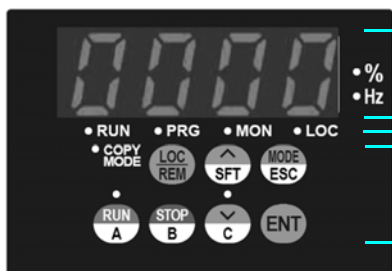

Front panel of the remote display terminal

Remote display terminal

The Altivar 21 drive can be connected to a remote display terminal. The display terminal can be mounted on the door of an enclosure with IP 50 protection on the front panel. The maximum operating temperature is 40°C.

Two types of operation are available:

- REMOTE KEYPAD MODE: This provides access to the same functions as the integrated 7-segment terminal and can be used:
 - To control, adjust and configure the drive remotely
 - For remote display
- COPY MODE: Configurations can be stored and downloaded (three configuration files can be stored).

Depending on the operating mode selected, the following keys have different functions:

- ^/SFT
- MODE/ESC
- RUN/A
- STOP/B
- ∨/C

Note: It is not possible to use the remote display terminal and a communication option card simultaneously. To be able to use the remote display terminal when the drive is equipped with a communication card, the network or communication bus must be deactivated.

Description

- 1 Display:
 - Four 7-segment displays visible at 5 m
 - Display of numeric values and codes
 - The display flashes when a value is stored
 - Unit rating of displayed value
 - The display flashes to indicate a fault on the drive
- 2 Display of drive status:
 - RUN: Run command is active or speed reference present
 - PRG: Drive in automatic mode
 - MON: Drive in monitoring mode
 - LOC: Drive in local mode
 - COPY MODE: COPY MODE selected
- 3 Use of keys:
 - LOC/REM: Switching of the drive command, locally or remotely
As a "local" command, the speed reference can be modified using the ^ and ∨ keys; the LED located between these keys lights up.
 - ^/SFT, depending on the operating mode selected:
 - Vertical navigation in the menu or editing of values
 - Access to functions for managing parameters (copy, comparison, protection) or to display terminal memories
 - MODE/ESC, depending on the operating mode selected:
 - To adjust and program drive parameters, access to monitoring mode
 - To abort a value or parameter to return to the previous state
 - RUN/A, depending on the operating mode selected:
 - Local motor run command; LED indicates that the RUN key is active
 - Copy terminal memory "A"
 - STOP/B, depending on the operating mode selected:
 - Local control of motor stopping/drive fault clearing
 - Copy terminal memory "B"
 - ∨/C, depending on the operating mode selected:
 - Vertical navigation in the menu or editing of values
 - Copy terminal memory "C"
 - ENT: Saves the current value or the selected function

Reference

Description	Reference	Weight kg
Remote display terminal	VW3 A21 101	0.250
Supplied with:		
■ 1 x 3.6 m cable with 2 RJ45 connectors		
■ Seal and screws for IP 50 mounting on an enclosure door		

Variable speed drives for asynchronous motors

Altivar 21

Communication buses and networks

2

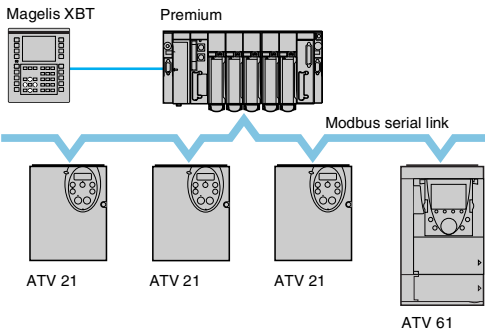

Example of configuration on the Modbus serial link

2.2

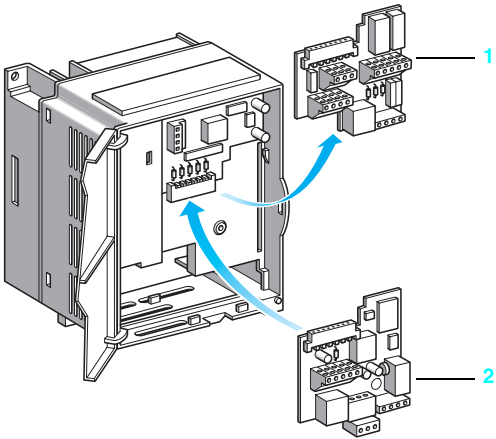

Presentation

The Altivar 21 drive is designed to suit the configurations found in communicating installations created for buildings.

It includes the Modbus communication protocol as standard (1).

The RJ45 Modbus port is located on the drive's control terminals. It is assigned to control and signaling by a PLC or by another type of controller.

It is also used to connect:

- The remote terminal
- A Magelis industrial HMI terminal

By substituting the I/O terminals 1 with one of the 4 communication cards 2 available as an option, the Altivar 21 drive can also be connected to other networks and communication buses in operation in the building (HVAC) (2). Each communication card contains I/O terminals.

Communication cards for building applications (HVAC):

- LONWORKS
- METASYS N2
- APOGEE FLN
- BACnet

Note: Connection to a network or communication bus via one of the four communication cards is incompatible with the use of the PCSoft software workshop or the remote display terminal. To be able to use the PCSoft software workshop or the remote display terminal, the network or communication bus must be deactivated. See pages 2/50 and 2/51.

(1) Modbus communication protocol characteristics (see page 2/43)

(2) Heating Ventilation & Air Conditioning

Variable speed drives for asynchronous motors

Altivar 21

Communication buses and networks

Functions

All the drive functions can be accessed via the network:

- Control
- Monitoring
- Adjustment
- Configuration

The speed command and reference may come from different control sources:

- I/O terminals
- Communication network
- Remote display terminal

The advanced functions of the Altivar 21 drive can be used to manage switching of these drive control sources according to the application requirements.

Communication is monitored according to criteria specific to each protocol.

The response of the drive in the event of a communication fault can be configured:

- Freewheel stop, stop on ramp or braked stop
- Maintain the last command received
- Ignore the fault

2

Characteristics of the VW3 A21 312 LONWORKS card

Structure	Connector	1 removable 3-way screw terminal
	Topology	TP/FT-10 (free topology)
	Transmission speed	78 kbps
Services	Functional profiles	LONMARK 6010: Variable Speed Motor Drive LONMARK 0000: Node Object
Diagnostics	Using LEDs	1 LED on the card: Service
	Using the graphic display terminal	Control word received Reference received
Description file		An xif file is supplied on the documentation CD-ROM or can be downloaded from the Internet at "www.telemecanique.com".

Characteristics of the VW3 A21 313 METASYS N2 card

Structure	Connector	1 removable 4-way screw terminal
Diagnostics	Using LEDs	1 LED on the card: "COM" (network traffic)
	Using the graphic display terminal	Control word received Reference received

Characteristics of the VW3 A21 314 APOGEE FLN card

Structure	Connector	1 removable 4-way screw terminal
Diagnostics	Using LEDs	1 LED on the card: "COM" (network traffic)
	Using the graphic display terminal	Control word received Reference received

Characteristics of the VW3 A21 315 BACnet card

Structure	Connector	1 removable 4-way screw terminal
Diagnostics	Using LEDs	1 LED on the card: "COM" (network traffic)
	Using the graphic display terminal	Control word received Reference received

2.2

Variable speed drives for asynchronous motors

Altivar 21

Communication buses and networks

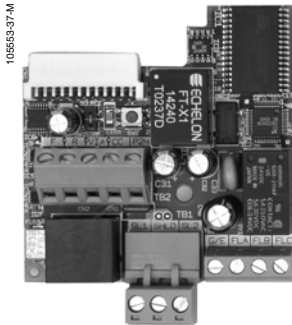

VW3 A21 312

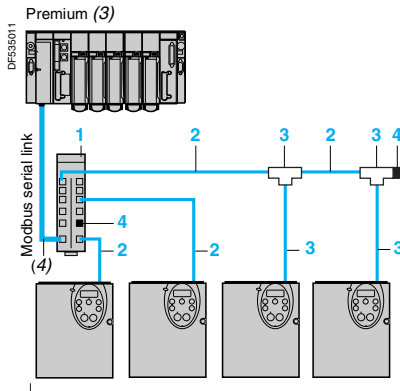

ATV 21

Example of Modbus diagram, connections via
splitter blocks and RJ45 connectors

Communication cards (1) (2)

Description	Use	Reference	Weight kg
LONWORKS	The card is equipped with a removable 3-way screw terminal block	VW3 A21 312	0.200
METASYS N2	The card is equipped with a removable 4-way screw terminal block	VW3 A21 313	0.200
APOGEE FLN	The card is equipped with a removable 4-way screw terminal block	VW3 A21 314	0.200
BACnet	The card is equipped with a removable 4-way screw terminal block	VW3 A21 315	0.200

Connection accessories

Description	Item no.	Length m	Unit reference	Weight kg
Modbus serial link				
Modbus splitter block 10 RJ45 connectors and 1 screw terminal block	1	–	LU9 GC3	0.500
Cables for Modbus serial link equipped with 2 RJ45 connectors	2	0.3	VW3 A8 306 R03	0.025
		1	VW3 A8 306 R10	0.060
		3	VW3 A8 306 R30	0.130
Modbus T-junction boxes (with integrated cable)	3	0.3	VW3 A8 306 TF03	–
		1	VW3 A8 306 TF10	–
Line terminator For RJ45 connector (5)	4	–	VW3 A8 306 RC	0.010

(1) The Altivar 21 drive can only take one communication card.

(2) The user manuals are supplied on CD-ROM or can be downloaded from the Internet at "www.telemecanique.com". The description file for the LONWORKS communication card is also supplied on CD-ROM in xif format or can be downloaded from the Internet at "www.telemecanique.com".

(3) Please refer to the "Automation platform Modicon Premium and Unity - PL7 software" and "Automation platform Modicon TSX Micro and PL7 software" catalogues.

(4) Cable depending on the type of controller or PLC.

(5) Order in multiples of 2.

Variable speed drives for asynchronous motors

Altivar 21: EMC filters

Optional integrated filters and additional filters

2

2.2

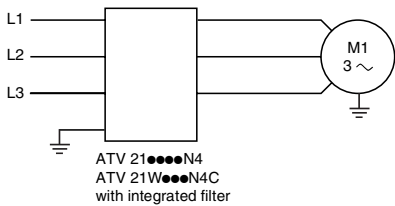

Integrated EMC filters

Altivar 21 drives, except for the ATV 21H●●●M3X, have built-in radio interference input filters to meet the requirements of the EMC standard for variable speed electrical power drive “products” IEC/EN 61800-3, edition 2, categories C1, C2 or C3 in environment 1 or 2 and to comply with the European directive on EMC (electromagnetic compatibility).

Drives	Maximum length of shielded cable (1) according to		Leakage current (2)
	EN 55011 class A Gr1 (3)	EN 55011 class B Gr1 (3)	
	IEC/EN 61800-3 (3)	IEC/EN 61800-3 (3)	mA
UL Type 1/IP 20 drives			
ATV 21H075N4...HU22N4	20	–	4.5
ATV 21HU30N4...HU55N4	5	–	5.8
ATV 21HU75N4, HD11N4	5	–	2.9
ATV 21HD15N4, HD18N4	5	–	4.8
ATV 21HD22N4, HD30N4	5	–	25.3
ATV 21HD37N4, HD45N4	20	–	21.5
ATV 21HD55N4, HD75N4	100	–	9.1
IP 54 drives			
ATV 21W075N4...WU22N4	5	–	4.5
ATV 21WU30N4...WU55N4	5	–	5.8
ATV 21WU75N4	5	–	2.9
ATV 21WD11N4, WD15N4	5	–	13.3
ATV 21WD18N4	5	–	9.4
ATV 21WD22N4, WD30N4	5	–	25.3
ATV 21WD37N4, WD45N4	20	–	21.5
ATV 21WD55N4, WD75N4	100	–	9.1
ATV 21W075N4C...WU22N4C	–	20	18.4
ATV 21WU30N4C...WU55N4C	–	20	42.8
ATV 21WU75N4C	–	20	37.2
ATV 21WD11N4C, WD15N4C	–	20	81
ATV 21WD18N4C	–	20	77.2
ATV 21WD22N4C, WD30N4C	–	20	84.5
ATV 21WD37N4C, WD45N4C	–	20	53.6
ATV 21WD55N4C, WD75N4C	–	20	56.9

Additional EMC input filters

Applications

Additional EMC input filters can be used to meet more stringent requirements and are designed to cut down conducted emissions on the line supply below the limits of standards EN 55011 group 1, class A or B and IEC/EN 61800-3 category C1, C2 or C3 (see page 2/38).

The additional EMC filters can be mounted beside or under the device. They act as a support for the drives and are attached to them via tapped holes.

Use according to the type of line supply

Use of these additional filters is only possible on TN (neutral connection) and TT (neutral to earth) type networks.

Standard IEC/EN 61800-3, appendix D2.1, states that on IT networks (isolated or impedance earthed neutral), filters can cause permanent insulation monitors to operate in a random manner.

In addition, the effectiveness of additional filters on this type of network depends on the type of impedance between neutral and earth, and therefore cannot be predicted. In the case of a machine which needs to be installed on an IT network, the solution would be to insert an isolation transformer and place the machine locally on a TN or TT network.

(1) Maximum lengths for shielded cables connecting motors to drives for a switching frequency of 6 to 16 kHz. If motors are connected in parallel, it is the total length that should be taken into account.

(2) Maximum earth leakage current at 480 V 60 Hz on a TT network.

(3) See page 2/38.

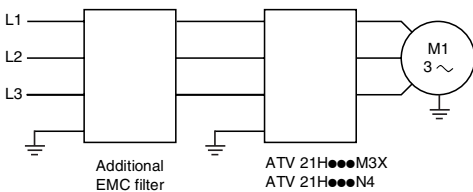

General characteristics

EMC filter type		VW3 A31 404, 406...409	VW3 A4 406...408
Conformity to standards		EN 133200	
Degree of protection		IP 20 and IP 41 on upper part	
Maximum relative humidity		93% without condensation or dripping water conforming to IEC 68-2-3	
Ambient air temperature around the unit	Operation	°C	-10...+60
	Storage	°C	-25...+70
Maximum operating altitude		m	1000 without derating. 1000...3000 derating the current by 1% per additional 100 m. Limited to 2000 m for the "Corner Grounded" distribution network.
Vibration resistance			1.5 mm peak to peak from 3...13 Hz, 1 gn peak from 13...150 Hz, in accordance with IEC 60068-2-6
Shock resistance			15 gn for 11 ms conforming to IEC/EN 60068-2-27
Maximum nominal voltage	50/60 Hz three-phase	V	240 +10% 480 +10%

Connection characteristics

Maximum wire size and tightening torque	VW3 A31 404, 406	10 mm ² (AWG 6) 1.8 Nm
	VW3 A31 407...409	25 mm ² (AWG 2) 4.5 Nm
	VW3 A4 406, 407	50 mm ² (AWG 0) 6 Nm
	VW3 A4 408	150 mm ² (300 kcmil) 25 Nm

References

For drives	Maximum length of shielded cable (1) according to		In (2)	II (3)	Loss (4)	Reference	Weight
	EN 55011 class A Gr1 (5)	EN 55011 class B Gr1 (5)					
	IEC/EN 61800-3 (5)	IEC/EN 61800-3 (5)					
	m	m	A	mA	W		kg
Three-phase supply voltage: 200...240 V 50/60 Hz							
ATV 21H075M3X	20	20	15	6.7	0.47	VW3 A31 404	1.000
ATV 21HU15M3X	20	20	15	6.7	1.6	VW3 A31 404	1.000
ATV 21HU22M3X	20	20	15	6.7	3.3	VW3 A31 404	1.000
ATV 21HU30M3X	20	20	25	17.8	3.6	VW3 A31 406	1.650
ATV 21HU40M3X	20	20	25	17.8	6.2	VW3 A31 406	1.650
ATV 21HU55M3X	20	–	47	20.6	3.7	VW3 A31 407	3.150
ATV 21HU75M3X	20	–	47	20.6	6.8	VW3 A31 407	3.150
ATV 21HD11M3X	20	–	83	14.5	9.1	VW3 A31 408	5.300
ATV 21HD15M3X	20	–	83	14.5	16	VW3 A31 408	5.300
ATV 21HD18M3X	20	–	83	14.5	23.1	VW3 A31 408	5.300
ATV 21HD22M3X	100	–	90	40.6	27.1	VW3 A4 406	15.000
ATV 21HD30M3X	20	–	180	86.3	23.1	VW3 A4 408	40.000
Three-phase supply voltage: 380...480 V 50/60 Hz							
ATV 21H075N4	20	20	15	13.8	0.13	VW3 A31 404	1.000
ATV 21HU15N4	20	20	15	13.8	0.45	VW3 A31 404	1.000
ATV 21HU22N4	20	20	25	13.8	0.9	VW3 A31 404	1.000
ATV 21HU30N4	20	20	25	37	1	VW3 A31 406	1.650
ATV 21HU40N4	20	20	25	37	1.6	VW3 A31 406	1.650
ATV 21HU55N4	20	20	25	37	3	VW3 A31 406	1.650
ATV 21HU75N4	20	20	47	42.8	1.9	VW3 A31 407	3.150
ATV 21HD11N4	20	20	47	42.8	3.9	VW3 A31 407	3.150
ATV 21HD15N4	20	20	49	42.8	9.2	VW3 A31 409	4.750
ATV 21HD18N4	20	20	49	42.8	13.8	VW3 A31 409	4.750
ATV 21HD22N4	100	–	90	84.5	7.3	VW3 A4 406	15.000
ATV 21HD30N4	100	–	90	84.5	13.5	VW3 A4 406	15.000
ATV 21HD37N4	100	100	92	106	16	VW3 A4 407	17.000
ATV 21HD45N4	100	100	92	106	23	VW3 A4 407	17.000
ATV 21HD55N4	100	100	180	193	18	VW3 A4 408	40.000
ATV 21HD75N4	100	100	180	193	34	VW3 A4 408	40.000

(1) The filter selection tables give the maximum lengths for shielded cables connecting motors to drives for a switching frequency of 6 to 16 kHz. These limits are given as examples only as they vary depending on the stray capacitance of the motors and the cables used. If motors are connected in parallel, it is the total length that should be taken into account.

(2) Filter nominal current.

(3) Maximum earth leakage current at 230 V and at 480 V 60 Hz on a TT network.

(4) Via thermal dissipation.

(5) See page 2/38.



VW3 A31 406

Variable speed drives for asynchronous motors

Altivar 21
UL Type 1/IP 20 drives

2

ATV 21H075M3X...HU40M3X, ATV 21H075N4...HU55N4

Plate for EMC mounting (supplied with the drive)

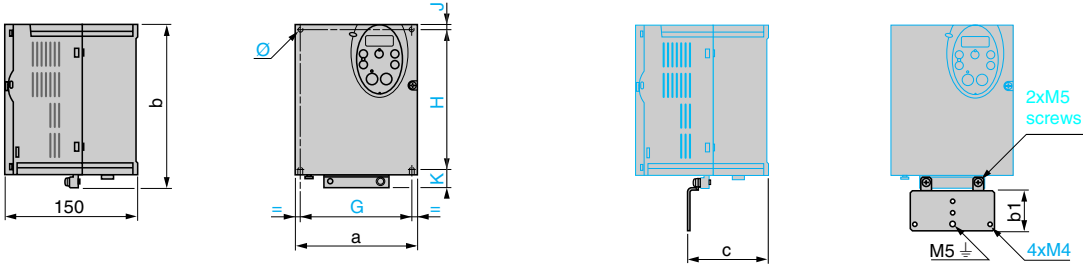

ATV 21H	a	b	b1	c	G	H	J	K	Ø
075M3X...U22M3X	107	143	49	67.3	93	121.5	5	16.5	2xØ5
075N4...U22N4									
U30M3X, U40M3X	142	184	48	88.8	126	157	6.5	20.5	4xØ5
U30N4...U55N4									

2.2

ATV 21HU55M3X, HU75M3X, ATV 21HU75N4, HD11N4

Plate for EMC mounting (supplied with the drive)

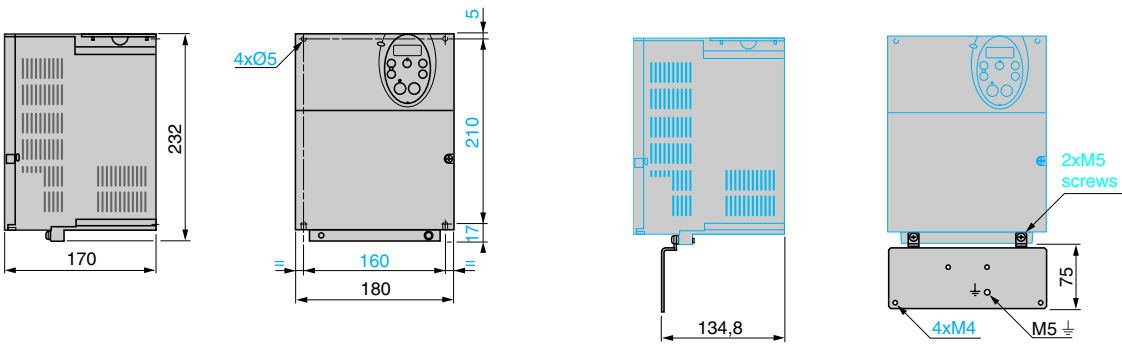

ATV 21HD11M3X...HD18M3X, ATV 21HD15N4, HD18N4

Plate for EMC mounting (supplied with the drive)

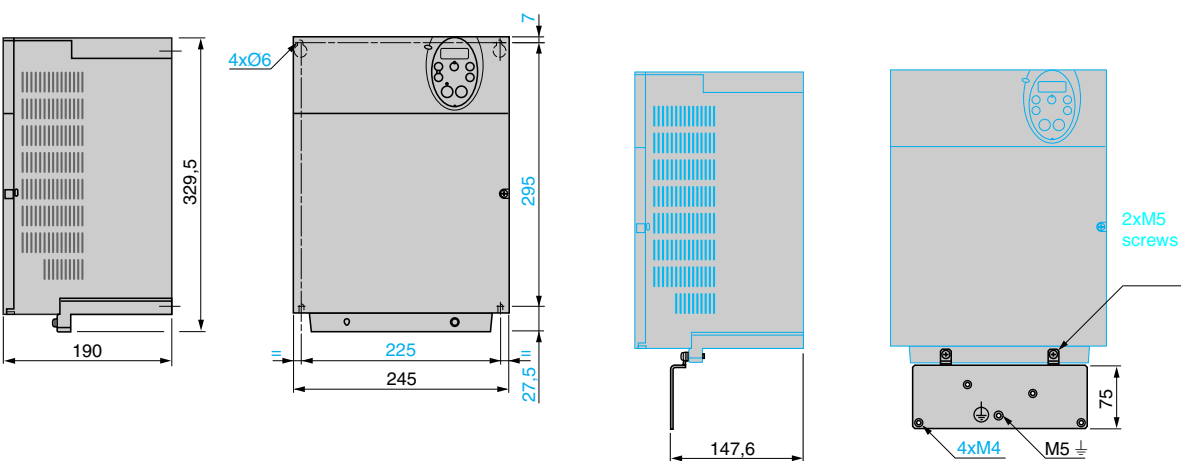

Variable speed drives for asynchronous motors

Altivar 21

UL Type 1/IP 20 drives

ATV 21HD22M3X, ATV 21HD22N4...HD45N4

EMC mounting plate (supplied with drive)

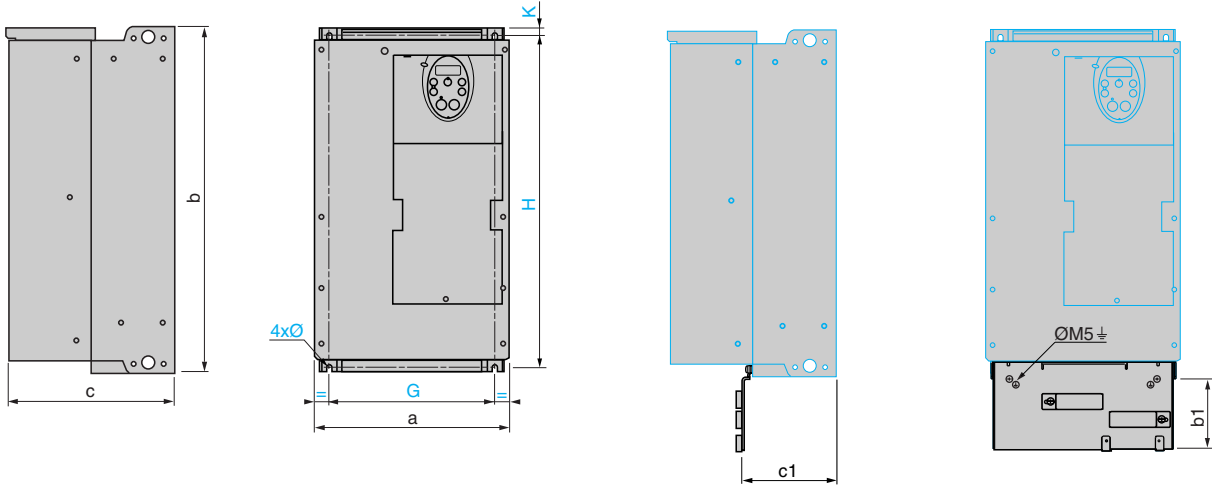

ATV 21H	a	b	b1	c	c1	G	H	K	Ø
D22M3X	240	420	122	214	120	206	403	10	6
D22N4, D30N4									
D37N4, D45N4	240	550	113	244	127	206	529	10	6

ATV 21HD30M3X

EMC mounting plate (supplied with drive)

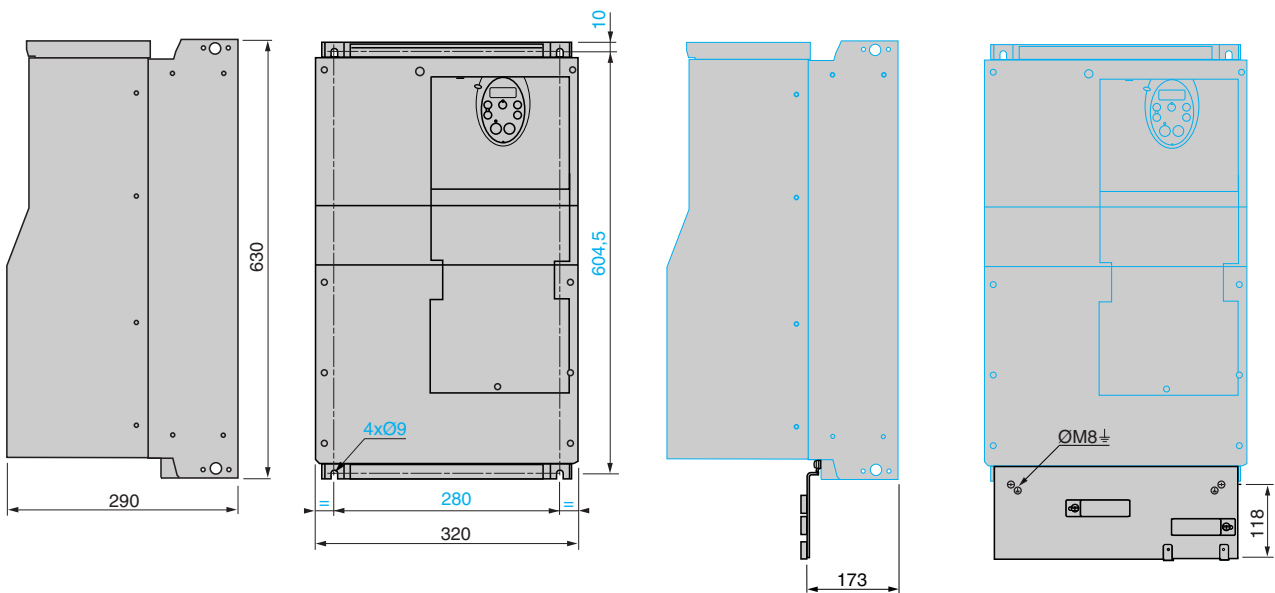

2

2.2

Variable speed drives for asynchronous motors

Altivar 21

IP 54 drives and accessories

2

ATV 21W075N4...WU75N4, ATV 21W075N4C...WU75N4C

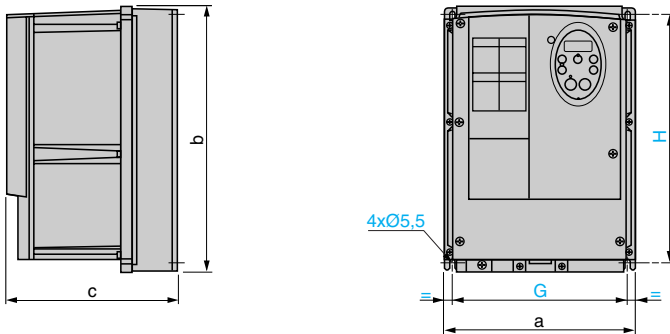

ATV 21W	a	b	c	G	H
075N4, U15N4	215	297	192	197	277
075N4C, U15N4C					
U22N4...U75N4	230	340	208	212	318
U22N4C...U75N4C					

2.2

ATV 21WD11N4...WD75N4, ATV 21WD11N4C...WD75N4C

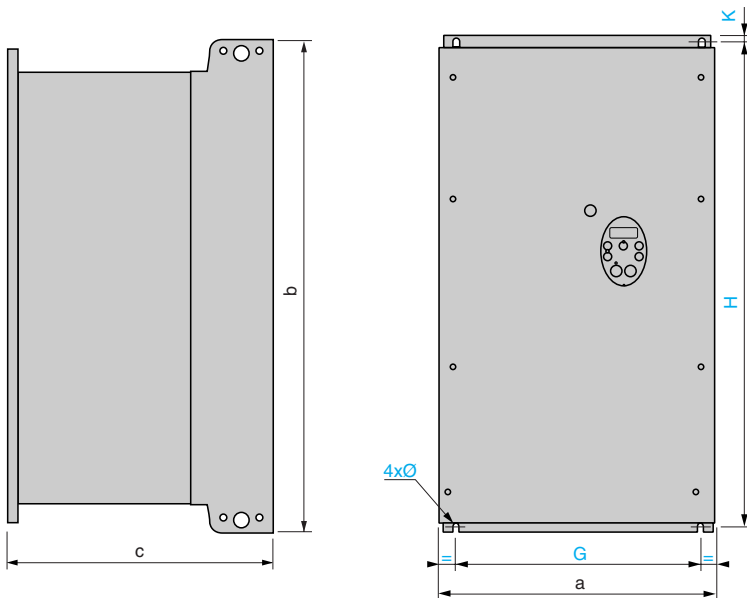

ATV 21W	a	b	c	G	H	K
D11N4, D15N4	290	560	315	250	544	8
D11N4C, D15N4C						
D18N4	310	665	315	270	650	10
D18N4C						
D22N4, D30N4	284	720	315	245	700	10
D22N4C, D30N4C						
D37N4, D45N4	284	880	343	245	860	10
D37N4C, D45N4C						
D55N4, D75N4	362	1000	364	300	975	10
D55N4C, D75N4C						

UL Type 1 conformity kits

VW3 A31 814...817

VW3 A9 206...208

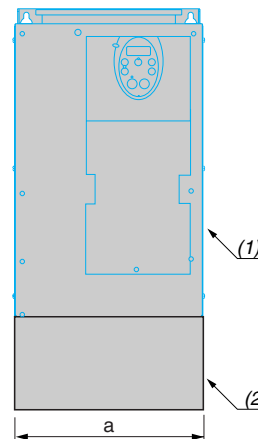
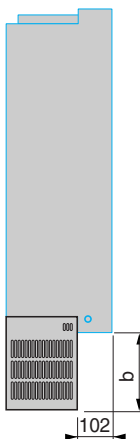
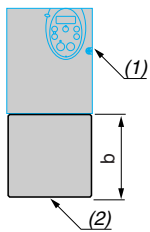

VW3	b
A31 814, 815	68
A31 816	96
A31 817	99

VW3	a	b
A9 206	240	59.9
A9 207	240	51.5
A9 208	320	136

(1) Drive
(2) Kit

(1) Drive
(2) Kit

Variable speed drives for asynchronous motors

Altivar 21

Accessories, dialogue and additional EMC input filters

Kits for mounting on rail

VW3 A31 852

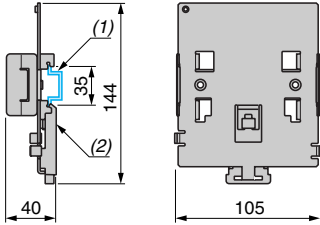

(1) rail
(2) Kit

Remote display terminal

VW3 A21 101

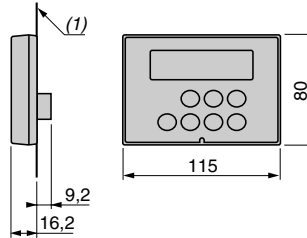

(1) Enclosure door

Cut-outs and drill holes

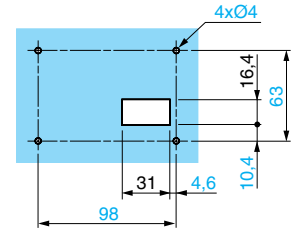

Additional EMC input filters

VW3 A31 404, 406...409

VW3 A4 406...408

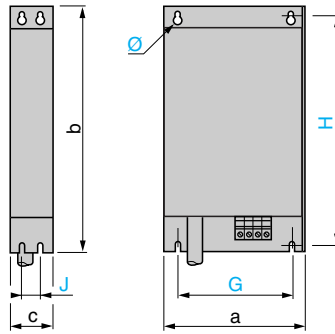
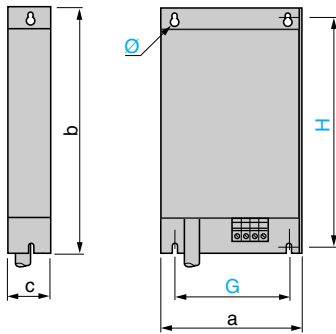

VW3	a	b	c	G	H	J	Ø
A31 404	107	195	42	85	180	-	4.5
A31 406	140	235	50	120	215	-	4.5
A31 407	180	305	60	140	285	-	5.5
A31 408	245	395	80	205	375	-	5.5
A31 409	245	395	60	205	375	-	5.5
A4 406	240	522	79	200	502.5	40	9
A4 407	240	650	79	200	631	40	9
A4 408	320	750	119	280	725	80	9

Mounting the filter under the drive

Front view

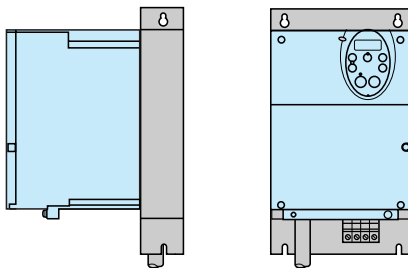

Mounting the filter next to the drive

Front view

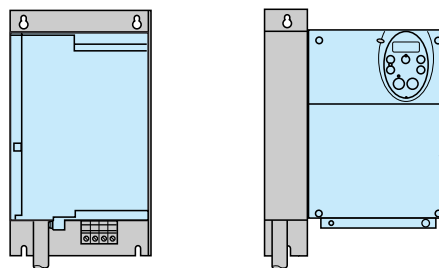

Front view

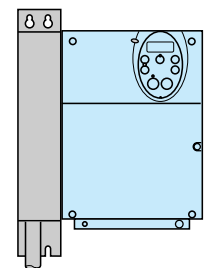

2

2.2

Recommended scheme for ATV 21H●●●M3X, ATV 21●●●●N4, ATV 21W●●●N4C

3-phase power supply

Switches (factory settings)

Voltage/current selection
for analog I/O (FM and VIA)

Selection of logic type

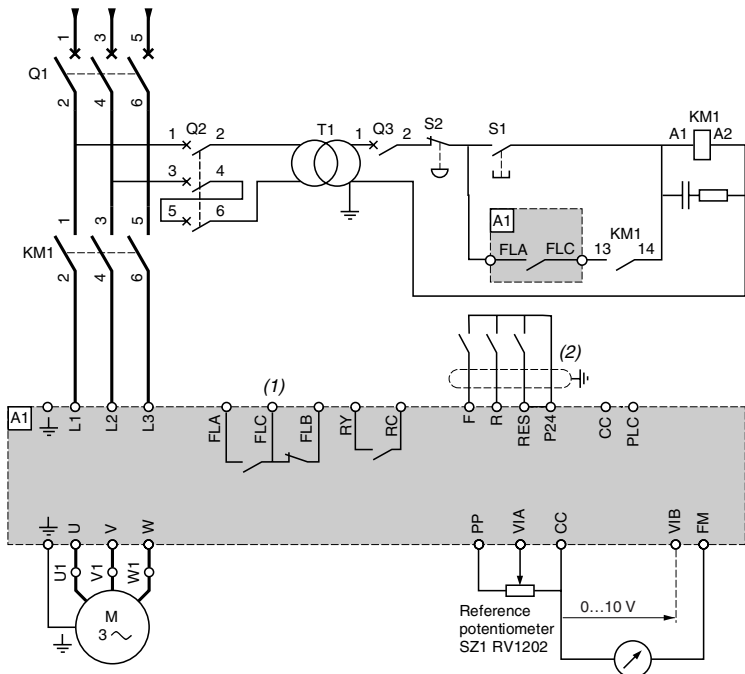
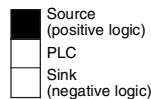
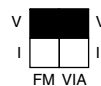

Note: All terminals are located at the bottom of the drive. Install interference suppressors on all inductive circuits near the drive or connected on the same circuit, such as relays, contactors, solenoid valves, fluorescent lighting, etc.

Compatible components (for a complete list of references, please consult the "Motor starter solutions. Control and protection components" catalogue).

Ref.	Description
A1	ATV 21 drive, see pages 2/48 and 2/49
KM1	Contactors, see pages 2/66 to 2/69
Q1	Circuit breaker, see pages 2/66 to 2/69
Q2	GV2 L rated at twice the nominal primary current of T1
Q3	GB2 CB05
S1, S2	XB2 B or XA2 B pushbuttons
T1	100 VA transformer 220 V secondary

(1) Fault relay contacts for remote signalling of the drive status

(2) Connection of the common for the logic inputs depends on the positioning of the switch ("Source", "PLC", "Sink"), see page 2/63.

Examples of recommended schemes

Logic inputs according to the position of the logic type switch

Source position

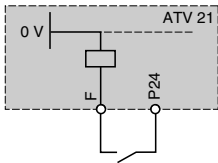

Sink position

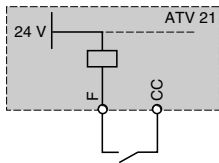

PLC position with PLC transistor outputs

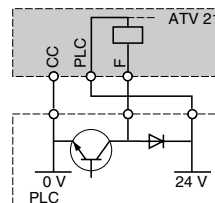
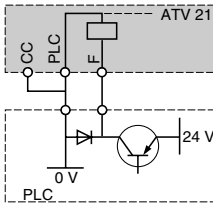

2-wire control

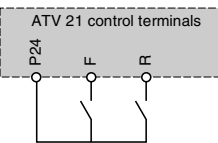

F: Forward
R: Preset speed

3-wire control

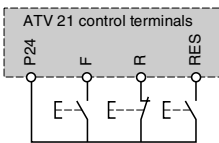

F: Forward
R: Stop
RES: Fault reset

PTC probe

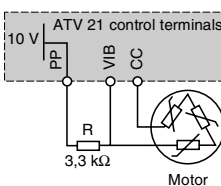

Motor

Voltage analog inputs

External + 10 V

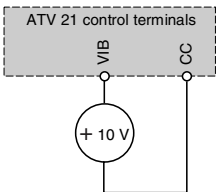
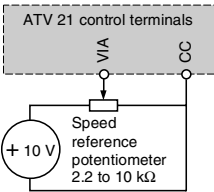

Analog input configured for current

0-20 mA, 4-20 mA, X-Y mA

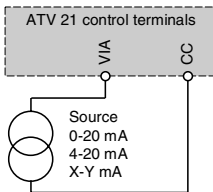

Analog input VIA configured as logic input

Positive logic (Source position)

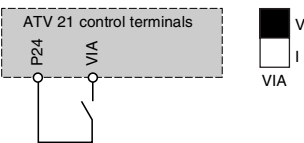

Negative logic (Sink position)

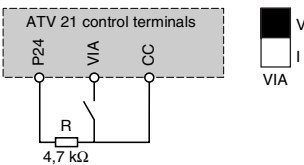

Additional EMC input filters VW3 A31 404, 406...409, VW3 A4 406...408

3-phase power supply

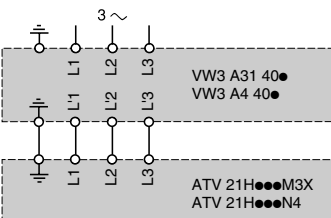

2

2.2

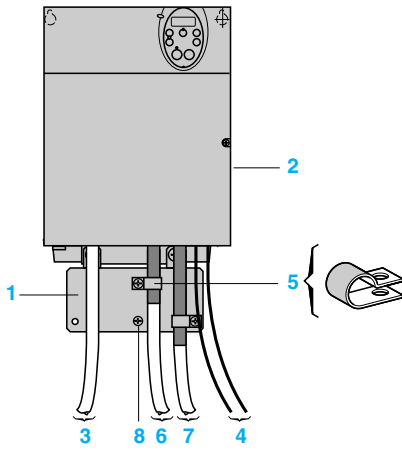

ATV 21H075M3X...HD18M3X,
ATV 21H075N4...HD18N4

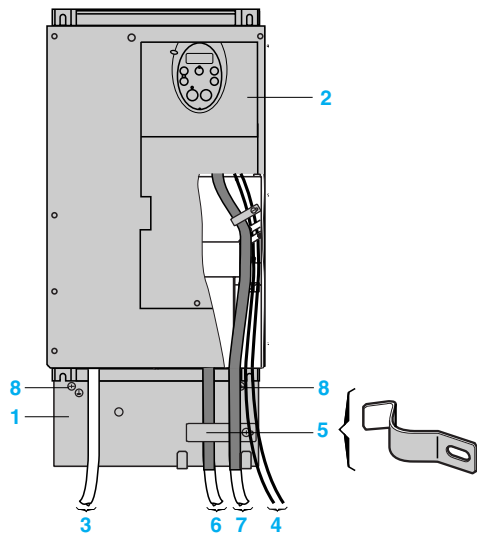

ATV 21HD22M3X, HD30M3X,
ATV 21HD22N4...HD75N4

Connections to meet the requirements of EMC standards

Principle

- Earths between the drive, motor and cable shielding must have "high frequency" equipotentiality.
- Use shielded cables with shielding connected to earth throughout 360° at both ends for the motor cable and the control-command cables. Conduit or metal ducting can be used for part of the shielding length provided that there is no break in the continuity of the earth connection.
- Ensure maximum separation between the power supply cable (line supply) and the motor cable.

Installation diagram for ATV 21H●●●M3X and ATV 21H●●●N4 drives

- 1 Steel plate to be mounted on the drive (earthed casing)
- 2 UL Type 1/IP 20 Altivar drive
- 3 Unshielded power supply wires or cable
- 4 Unshielded wires for the output of the fault relay contacts
- 5 Attach and earth the shielding of cables 6 and 7 as close as possible to the drive:
 - Strip the shielding.
 - Attach the cable to the metal plate 1 by tightening the clamp on the stripped part of the shielding.
 The shielding must be clamped tightly enough to the metal plate to ensure good contact.
- 6 Shielded cable for connecting the motor
- 7 Shielded cable for connecting the control/signal wiring
 - For applications requiring several conductors, use cables with a small cross-section (0.5 mm²).
 - For cables 6 and 7, the shielding must be earthed at both ends. The shielding must be continuous and intermediate terminals must be placed in EMC shielded metal boxes.
- 8 Earthing screw. Use this screw for the motor cable on low power rated drives, as the screw on the heatsink is inaccessible.

Note: The HF equipotential earth connection between the drive, motor and cable shielding does not remove the need to connect the PE conductors (green-yellow) to the appropriate terminals on each unit.

If using an additional EMC input filter, it should be mounted beneath the drive and connected directly to the line supply via an unshielded cable. Link 3 on the drive is then via the filter output cable.

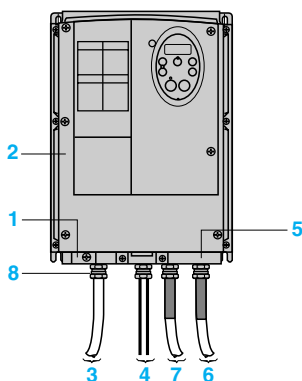

ATV 21W075N4...WU75N4,
ATV 21W075N4C...WU75N4C

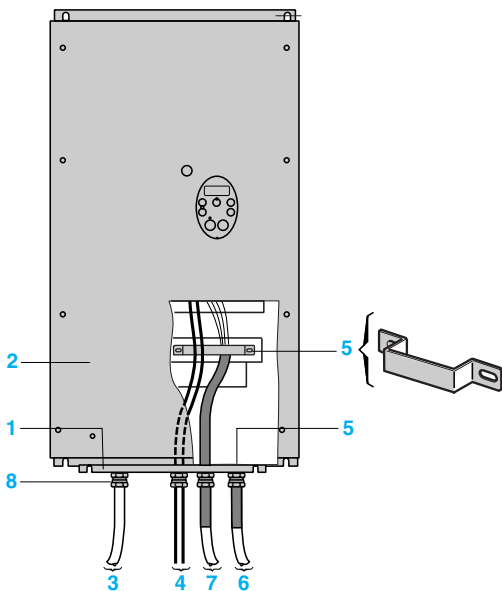

ATV 21WD11N4...WD30N4,
ATV 21WD11N4C...WD75N4C

Connections to meet the requirements of EMC standards (continued)

Installation diagram for ATV 21W●●●N4, ATV 21W●●●N4C drives

- 1 Steel plate (earthed casing)
- 2 Altivar 21 IP 54 drive
- 3 Unshielded power supply wires or cable
- 4 Unshielded wires for the output of the fault relay contacts
- 5 Attach and earth the shielding for cables 6 and 7 as close as possible to the drive:
 - Strip the shielding.
 - Attach the shielded cable to the cable gland 8 ensuring it is fully in contact throughout 360°.
 - Fold back the shielding and clamp it between the ring and the body of the cable gland.
 Depending on the drive rating, the shielding of cable 7 can be earthed using a cable gland 8 or a cable clamp 5. The shielding must be clamped tightly enough to the metal plate to ensure good contact.
- 6 Shielded cable for connecting the motor
- 7 Shielded cable for connecting the control/signal wiring
 - For applications requiring several conductors, use cables with a small cross-section (0.5 mm²).
 - For cables 6 and 7, the shielding must be connected to the earth at both ends. The shielding must be continuous and intermediate terminals must be placed in EMC shielded metal boxes.
- 8 Metal cable gland (not supplied) for cables 6 and 7.
Standard cable gland (not supplied) for cables 3 and 4.

Note: The HF equipotential earth connection between the drive, motor and cable shielding does not remove the need to connect the PE conductors (green-yellow) to the appropriate terminals on each unit.

Operation on an IT system

IT system: Isolated or impedance earthed neutral

Use a permanent insulation monitor compatible with non-linear loads, such as a Merlin Gerin type XM200 (please consult your Regional Sales Office).

ATV 21●●●N4 and ATV 21W●●●N4C drives have built-in EMC filters. These filters can be easily disconnected if using an IT system and subsequently reconnected if necessary.



GV2 L08
+ LC1 D09●●
+ ATV 21H075M3X

Applications

Circuit-breaker/contactor/drive combinations can be used to ensure continuous service of the installation with optimum safety.

The type of circuit-breaker/contactor coordination selected can reduce maintenance costs in the event of a motor short-circuit by minimizing the time required to make the necessary repairs and the cost of replacement equipment. The suggested combinations provide type 1 or type 2 coordination depending on the drive rating.

Type 2 coordination: A motor short-circuit will not damage the device or affect its settings. The motor starter should be able to operate once the electrical fault has been removed. The electrical isolation provided by the circuit-breaker will not be affected by the short-circuit. Welding of the contactor contacts is permissible if they can be separated easily.

Type 1 coordination: The electrical isolation provided by the circuit-breaker will not be affected by the incident and no other elements apart from the contactor are damaged as a result of the motor short-circuit.

The drive controls the motor, provides protection against short-circuits between the drive and the motor and protects the motor cable against overloads. The overload protection is provided by the drive's motor thermal protection. If this protection is removed, external thermal protection should be provided.

Before restarting the installation, the cause of the trip must be removed.

Motor starters for UL Type 1/IP 20 drives

Motor Power (1)	Drive Reference	Circuit-breaker Reference (2)		Line contactor Reference (3) (4)	
		Rating	Im	A	A
Three-phase supply voltage: 200...240 V 50/60 Hz. Type 2 coordination					
0.75	1	ATV 21H075M3X	GV2 L08	4	LC1 D09●●
1.5	2	ATV 21HU15M3X	GV2 L10	6.3	LC1 D09●●
2.2	3	ATV 21HU22M3X	GV2 L14	10	LC1 D09●●
3	–	ATV 21HU30M3X	GV2 L16	14	LC1 D09●●
4	5	ATV 21HU40M3X	GV2 L20	18	LC1 D09●●
5.5	7.5	ATV 21HU55M3X	GV2 L22	25	LC1 D09●●
7.5	10	ATV 21HU75M3X	GV2 L32	32	LC1 D18●●
11	15	ATV 21HD11M3X	NS80HMA50	50	LC1 D32●●
15	20	ATV 21HD15M3X	NS80HMA80	80	LC1 D40●●
18.5	25	ATV 21HD18M3X	NS100●MA100	100	LC1 D80●●
22	30	ATV 21HD22M3X	NS100●MA100	100	LC1 D80●●
30	40	ATV 21HD30M3X	NS160●MA150	150	LC1 D115●●
Three-phase supply voltage: 200...240 V 50/60 Hz. Type 1 coordination					
0.75	1	ATV 21H075M3X	GV2 LE08	4	LC1 K06●●
1.5	2	ATV 21HU15M3X	GV2 LE10	6.3	LC1 K06●●
2.2	3	ATV 21HU22M3X	GV2 LE14	10	LC1 K06●●
3	–	ATV 21HU30M3X	GV2 LE16	14	LC1 K06●●
4	5	ATV 21HU40M3X	GV2 LE20	18	LC1 K06●●
5.5	7.5	ATV 21HU55M3X	GV2 LE22	25	LC1 D09●●
7.5	10	ATV 21HU75M3X	GV2 LE32	32	LC1 D18●●
11	15	ATV 21HD11M3X	NS80HMA50	50	LC1 D32●●
15	20	ATV 21HD15M3X	NS80HMA80	80	LC1 D40●●
18.5	25	ATV 21HD18M3X	NS100●MA100	100	LC1 D50●●
22	30	ATV 21HD22M3X	NS100●MA100	100	LC1 D80●●
30	40	ATV 21HD30M3X	NS160●MA150	150	LC1 D115●●

(1) Standard power ratings for 4-pole motors 50/60 Hz 230 V. The values expressed in HP comply with the NEC (National Electrical Code).

(2) NS80HMA●●, NS100●MA●●●: Products sold under the Merlin Gerin brand.

Breaking capacity of circuit-breakers according to standard IEC60947-2:

Circuit breaker	Icu (kA) for 240 V	N			H			L		
GV2 L08...GV2 L20 GV2 LE08...GV2 LE20	100	–	–	–	–	–	–	–	–	
GV2 L22, GV2 L32, GV2 LE22, GV2 LE32	50	–	–	–	–	–	–	–	–	
NS80HMA	100	–	–	–	–	–	–	–	–	
NS●●●MA	–	85	–	–	100	–	–	150	–	

(3) Composition of contactors:

LC1 K06, LC1 D09 to LC1 D115: 3 poles + 1 "N/O" auxiliary contact and 1 "N/C" auxiliary contact.

Replace ●● with the control circuit voltage reference indicated in the table below.

	Volts ~	24	48	110	220	230	240
LC1 K06	50/60 Hz	B7	E7	F7	M7	P7	U7
LC1 D09...D115	50 Hz	B5	E5	F5	M5	P5	U5
	60 Hz	B6	E6	F6	M6	–	U6
	50/60 Hz	B7	E7	F7	M7	P7	U7

For other voltages available between 24 V and 660 V, or a DC control circuit, please consult your Regional Sales Office.

Variable speed drives for asynchronous motors

Altivar 21

Motor starters: supply voltage 380...415 V

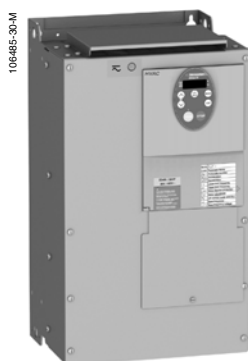

NS80HMA50
+
LC1 D32●●
+
ATV 21HD22N4

Motor starters for UL Type 1/IP 20 drives (continued)

Motor Power (1)		Drive Reference	Circuit breaker Reference (2)	Rating	Im	Line contactor Reference (3) (4)
kW	HP			A	A	
Three-phase supply voltage: 380...415 V 50/60 Hz. Type 2 coordination						
0.75	1	ATV 21H075N4	GV2 L07	2.5	–	LC1 D09●●
1.5	2	ATV 21HU15N4	GV2 L08	4	–	LC1 D09●●
2.2	3	ATV 21HU22N4	GV2 L10	6.3	–	LC1 D09●●
3	–	ATV 21HU30N4	GV2 L10	6.3	–	LC1 D09●●
4	5	ATV 21HU40N4	GV2 L14	10	–	LC1 D09●●
5.5	7.5	ATV 21HU55N4	GV2 L16	14	–	LC1 D09●●
7.5	10	ATV 21HU75N4	GV2 L20	18	–	LC1 D09●●
11	15	ATV 21HD11N4	GV2 L22	25	–	LC1 D09●●
15	20	ATV 21HD15N4	GV2 L32	32	–	LC1 D18●●
18.5	25	ATV 21HD18N4	NS80HMA50	50	300	LC1 D32●●
22	30	ATV 21HD22N4	NS80HMA50	50	300	LC1 D32●●
30	40	ATV 21HD30N4	NS80HMA80	80	480	LC1 D40●●
37	50	ATV 21HD37N4	NS80HMA80	80	480	LC1 D80●●
45	60	ATV 21HD45N4	NS100●MA100	100	600	LC1 D115●●
55	75	ATV 21HD55N4	NS100●MA150	150	1350	LC1 D115●●
75	100	ATV 21HD75N4	NS100●MA220	220	1980	LC1 F185●●
Three-phase supply voltage: 380...415 V 50/60 Hz. Type 1 coordination						
0.75	1	ATV 21H075N4	GV2 LE07	2.5	–	LC1 K06●●
1.5	2	ATV 21HU15N4	GV2 LE08	4	–	LC1 K06●●
2.2	3	ATV 21HU22N4	GV2 LE10	6.3	–	LC1 K06●●
3	–	ATV 21HU30N4	GV2 LE10	6.3	–	LC1 K06●●
4	5	ATV 21HU40N4	GV2 LE14	10	–	LC1 K06●●
5.5	7.5	ATV 21HU55N4	GV2 LE16	14	–	LC1 K06●●
7.5	10	ATV 21HU75N4	GV2 LE20	18	–	LC1 K06●●
11	15	ATV 21HD11N4	GV2 LE22	25	–	LC1 D09●●
15	20	ATV 21HD15N4	GV2 LE32	32	–	LC1 D18●●
18.5	25	ATV 21HD18N4	NS80HMA50	50	300	LC1 D32●●
22	30	ATV 21HD22N4	NS80HMA50	50	300	LC1 D32●●
30	40	ATV 21HD30N4	NS80HMA80	80	480	LC1 D40●●
37	50	ATV 21HD37N4	NS80HMA80	80	480	LC1 D80●●
45	60	ATV 21HD45N4	NS100●MA100	100	600	LC1 D115●●
55	75	ATV 21HD55N4	NS100●MA150	150	1350	LC1 D115●●
75	100	ATV 21HD75N4	NS100●MA220	220	1980	LC1 D115●●

(1) Standard power ratings for 4-pole motors 50/60 Hz 400 V.

The values expressed in HP comply with the NEC (National Electrical Code).

(2) NS80HMA●●, NS100●MA●●●: Products sold under the Merlin Gerin brand.

For references to be completed, replace the dot with the letter corresponding to the circuit-breaker breaking performance (N, H, L).

Breaking capacity of circuit-breakers according to standard IEC 60947-2:

Circuit breaker	Icu (kA) for 400 V			
	N	H	L	
GV2 L07...L14	100	–	–	–
GV2 L16...L32	50	–	–	–
GV2 LE07...LE22	15	–	–	–
GV2 LE32	10	–	–	–
NS80HMA	70	–	–	–
NS100●MA	–	25	70	150

(3) Composition of contactors:

LC1 K06, LC1 D09 to LC1 D115: 3 poles + 1 "N/O" auxiliary contact and 1 "N/C" auxiliary contact.

LC1 F185: 3 poles. To add auxiliary contacts or other accessories, please refer to the "Motor-starter solutions - Control and protection components" catalogue.

Replace ●● with the control circuit voltage reference indicated in the table below:

	Volts ~	24	48	110	220	230	240
		B7	E7	F7	M7	P7	U7
LC1 K06	50/60 Hz	B7	E7	F7	M7	P7	U7
LC1 D09...D115	50 Hz	B5	E5	F5	M5	P5	U5
	60 Hz	B6	E6	F6	M6	–	U6
LC1 F185	50/60 Hz	B7	E7	F7	M7	P7	U7
	50 Hz (LX1 coil)	B5	E5	F5	M5	P5	U5
	60 Hz (LX1 coil)	–	E6	F6	M6	–	U6
	40...400 Hz (LX9 coil)	–	E7	F7	M7	P7	U7

For other voltages available between 24 V and 660 V, or a DC control circuit, please consult your Regional Sales Office.

Variable speed drives for asynchronous motors

Altivar 21

Motor starters: supply voltage 380...415 V

Motor starters for IP 54 drives

Motor Power (1) kW	Drive HP	Circuit breaker		Rating Im A	Line contactor Reference (3) (4)	
		Reference	Reference (2)			
Three-phase supply voltage: 380...415 V 50/60 Hz. Type 2 coordination						
0.75	1	ATV 21W075N4 ATV 21W075N4C	GV2 L07	2.5	–	LC1 D09●●
1.5	2	ATV 21WU15N4 ATV 21WU15N4C	GV2 L08	4	–	LC1 D09●●
2.2	3	ATV 21WU22N4 ATV 21WU22N4C	GV2 L10	6.3	–	LC1 D09●●
3	–	ATV 21WU30N4 ATV 21WU30N4C	GV2 L10	6.3	–	LC1 D09●●
4	5	ATV 21WU40N4 ATV 21WU40N4C	GV2 L14	10	–	LC1 D09●●
5.5	7.5	ATV 21WU55N4 ATV 21WU55N4C	GV2 L16	14	–	LC1 D09●●
7.5	10	ATV 21WU75N4 ATV 21WU75N4C	GV2 L20	18	–	LC1 D09●●
11	15	ATV 21WD11N4 ATV 21WD11N4C	GV2 L22	25	–	LC1 D09●●
15	20	ATV 21WD15N4 ATV 21WD15N4C	GV2 L32	32	–	LC1 D18●●
18.5	25	ATV 21WD18N4 ATV 21WD18N4C	NS80HMA50	50	300	LC1 D25●●
22	30	ATV 21WD22N4 ATV 21WD22N4C	NS80HMA50	50	300	LC1 D32●●
30	40	ATV 21WD30N4 ATV 21WD30N4C	NS80HMA80	80	480	LC1 D40●●
37	50	ATV 21WD37N4 ATV 21WD37N4C	NS80HMA80	80	480	LC1 D80●●
45	60	ATV 21WD45N4 ATV 21WD45N4C	NS100●MA100	100	600	LC1 D80●●
55	75	ATV 21WD55N4 ATV 21WD55N4C	NS100●MA150	150	1350	LC1 D115●●
75	100	ATV 21WD75N4 ATV 21WD75N4C	NS100●MA150	150	1350	LC1 D115●●

(1) Standard power ratings for 4-pole motors 50/60 Hz 400 V.
The values expressed in HP comply with the NEC (National Electrical Code).
(2) NS80HMA●●, NS100●MA●●●: Products sold under the Merlin Gerin brand.
Breaking capacity of circuit-breakers according to standard IEC60947-2:

Circuit breaker	Icu (kA) for 400 V		
	N	H	L
GV2 L07...L14	100	–	–
GV2 L16...L32	50	–	–
NS80HMA	70	–	–
NS100●MA	–	25	70

(3) Composition of contactors:
LC1 D09 to LC1 D115: 3 poles + 1 "N/O" auxiliary contact and 1 "N/C" auxiliary contact.
(4) Replace ●● with the control circuit voltage reference indicated in the table below.

LC1 D09...D115	Volts ~	24	48	110	220	230	240
		50 Hz	B5	E5	F5	M5	P5
60 Hz	B6	E6	F6	M6	–	U6	
50/60 Hz	B7	E7	F7	M7	P7	U7	

For other voltages available between 24 V and 660 V, or a DC control circuit, please consult your Regional Sales Office.



GV2 L07
+
LC1 D09●●
+
ATV 21W075N4

2

2.2

Variable speed drives for asynchronous motors

Altivar 21

Motor starters: supply voltage 380...415 V



NS80HMA50
+
LC1 D25●●
+
ATV 21WD18N4

Motor starters for IP 54 drives (continued)

Motor Power (1) kW	HP	Drive Reference	Circuit breaker		Line contactor	
			Reference (2)	Rating A	Im A	Reference (3) (4)
Three-phase supply voltage: 380...415 V 50/60 Hz. Type 1 coordination						
0.75	1	ATV 21W075N4 ATV 21W075N4C	GV2 LE07	2.5	–	LC1 K06●●
1.5	2	ATV 21WU15N4 ATV 21WU15N4C	GV2 LE08	4	–	LC1 K06●●
2.2	3	ATV 21WU22N4 ATV 21WU22N4C	GV2 LE10	6.3	–	LC1 K06●●
3	–	ATV 21WU30N4 ATV 21WU30N4C	GV2 LE10	6.3	–	LC1 K06●●
4	5	ATV 21WU40N4 ATV 21WU40N4C	GV2 LE14	10	–	LC1 K06●●
5.5	7.5	ATV 21WU55N4 ATV 21WU55N4C	GV2 LE16	14	–	LC1 K06●●
7.5	10	ATV 21WU75N4 ATV 21WU75N4C	GV2 LE20	18	–	LC1 K06●●
11	15	ATV 21WD11N4 ATV 21WD11N4C	GV2 LE22	25	–	LC1 D09●●
15	20	ATV 21WD15N4 ATV 21WD15N4C	GV2 LE32	32	–	LC1 D18●●
18.5	25	ATV 21WD18N4 ATV 21WD18N4C	NS80HMA50	50	300	LC1 D25●●
22	30	ATV 21WD22N4 ATV 21WD22N4C	NS80HMA50	50	300	LC1 D32●●
30	40	ATV 21WD30N4 ATV 21WD30N4C	NS80HMA80	80	480	LC1 D40●●
37	50	ATV 21WD37N4 ATV 21WD37N4C	NS80HMA80	80	480	LC1 D50●●
45	60	ATV 21WD45N4 ATV 21WD45N4C	NS100●MA100	100	600	LC1 D80●●
55	75	ATV 21WD55N4 ATV 21WD55N4C	NS100●MA150	150	1350	LC1 D80●●
75	100	ATV 21WD75N4 ATV 21WD75N4C	NS100●MA150	150	1350	LC1 D115●●

- (1) Standard power ratings for 4-pole motors 50/60 Hz 400 V.
The values expressed in HP comply with the NEC (National Electrical Code).
(2) NS80HMA●●, NS100pMA●●●: Products sold under the Merlin Gerin brand.
Breaking capacity of circuit-breakers according to standard IEC60947-2:

Circuit breaker	Icu (kA) for 400 V		
	N	H	L
GV2 LE07...LE14	100	–	–
GV2 LE16...LE22	15	–	–
GV2 LE32	10	–	–
NS80HMA	70	–	–
NS100●MA	–	25	70

- (3) Composition of contactors:
LC1 K06, LC1 D09 to LC1 D115: 3 poles + 1 "N/O" auxiliary contact and 1 "N/C" auxiliary contact.
(4) Replace ●● with the control circuit voltage reference indicated in the table below.

	Volts ~	24	48	110	220	230	240
LC1 K06	50/60 Hz	B7	E7	F7	M7	P7	U7
LC1 D09...D115	50 Hz	B5	E5	F5	M5	P5	U5
	60 Hz	B6	E6	F6	M6	–	U6
	50/60 Hz	B7	E7	F7	M7	P7	U7

For other voltages available between 24 V and 660 V, or a DC control circuit, please consult your Regional Sales Office.

Mounting recommendations

Depending on the conditions in which the drive is to be used, its installation will require certain precautions and the use of appropriate accessories.

Install the unit vertically:

- Do not place it close to heating elements.
- Leave sufficient free space to ensure that the air required for cooling purposes can circulate from the bottom to the top of the unit.

ATV 21H●●●M3X, ATV 21H●●●N4

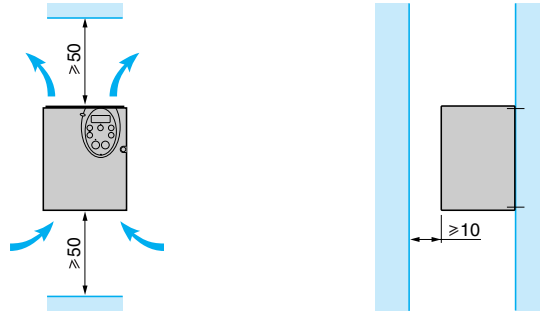

2

2.2

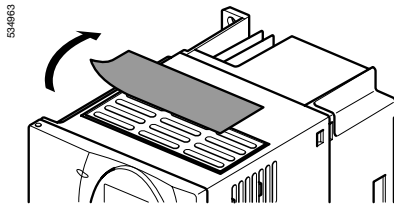

Removing the protective blanking cover for:
ATV 21H075M3X...HD18M3X,
ATV 21H075N4...HD18N4

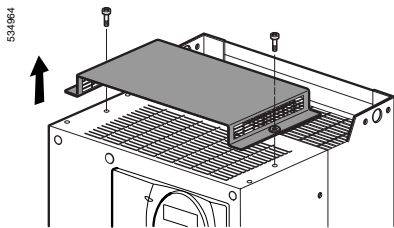

Removing the protective blanking cover for:
ATV 21HD22M3X, HD30M3X,
ATV 21HD22N4...HD75N4

Mounting types

■ Type A mounting

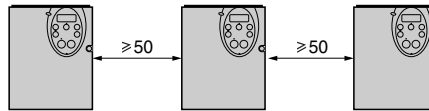

■ Type B mounting

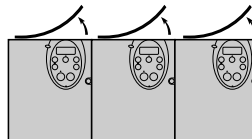

■ Type C mounting

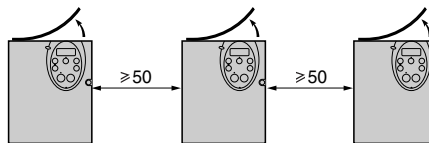

By removing the protective blanking cover from the top of the drive, the degree of protection for the drive becomes IP 20. The protective blanking cover may vary according to the drive model, see opposite.

Mounting recommendations (continued)

Derating curves

The derating curves for the drive nominal current (I_n) depend on the temperature, the switching frequency and the mounting type.

For intermediate temperatures (45°C for example), interpolate between 2 curves.

ATV 21H075M3X

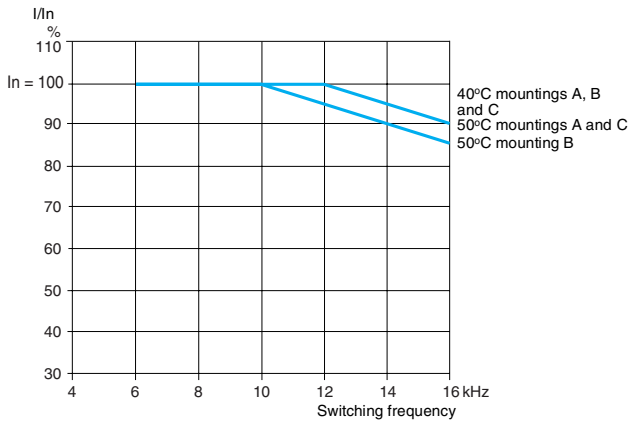

ATV 21HU15M3X, HU22M3X

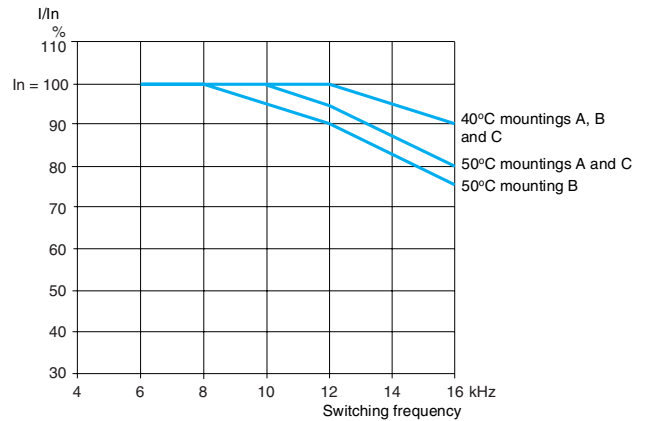

ATV 21HU30M3X

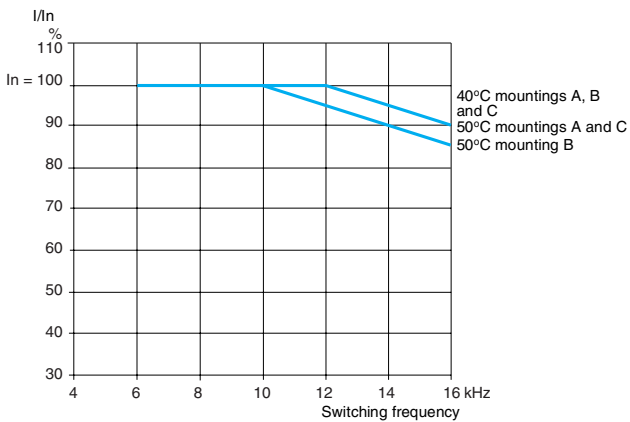

ATV 21HU40M3X

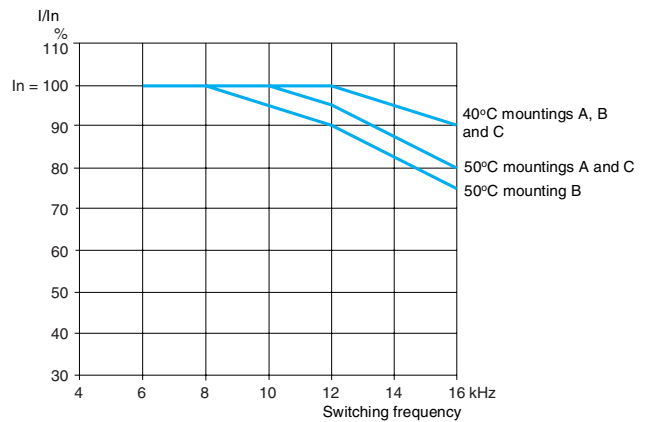

2

2.2

Mounting recommendations (continued)

Derating curves

ATV 21HU55M3X...HD15M3X

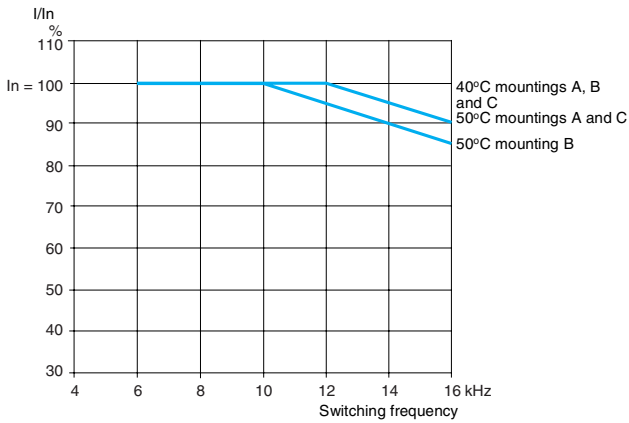

ATV 21HD18M3X

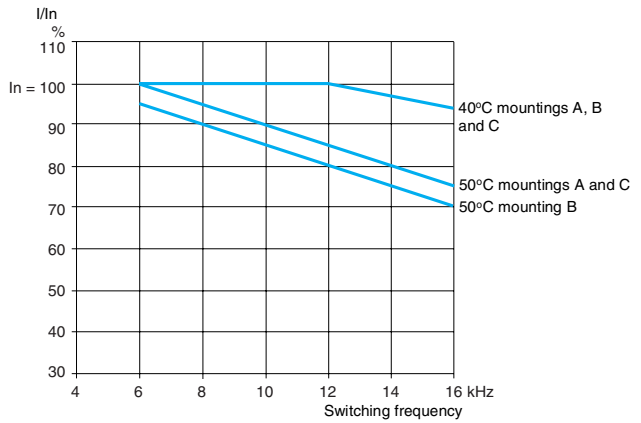

ATV 21HD22M3X

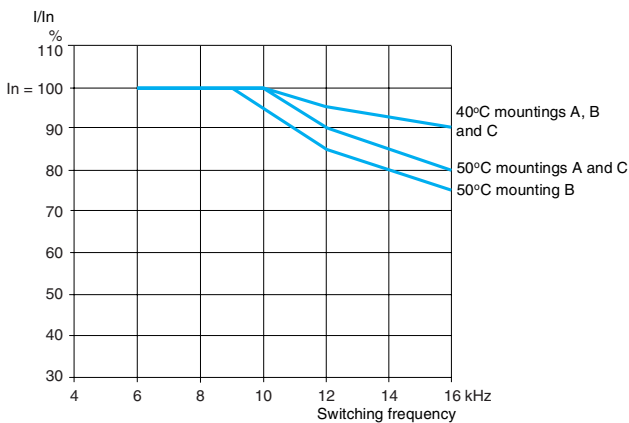

ATV 21HD30M3X

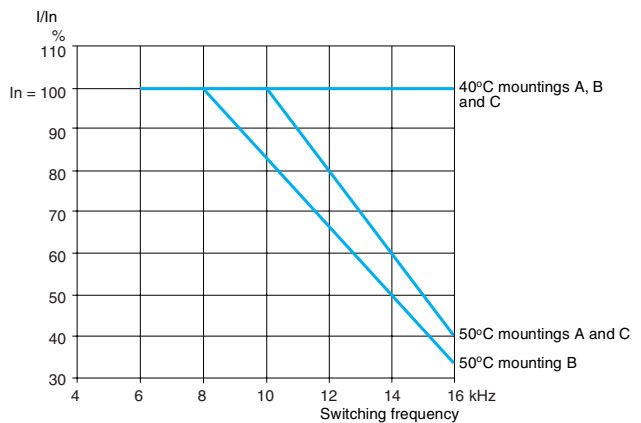

ATV 21H075N4, HU15N4

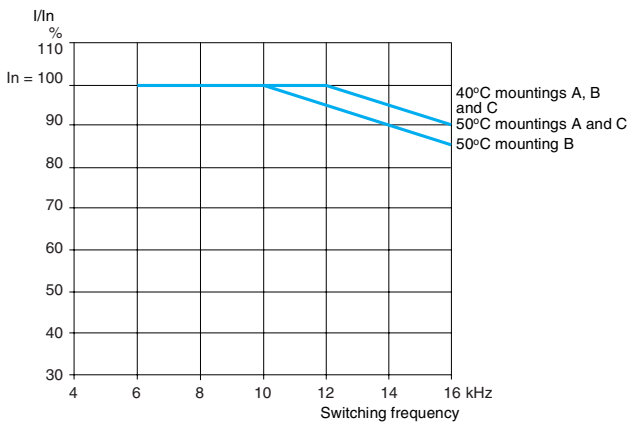

ATV 21HU22N4

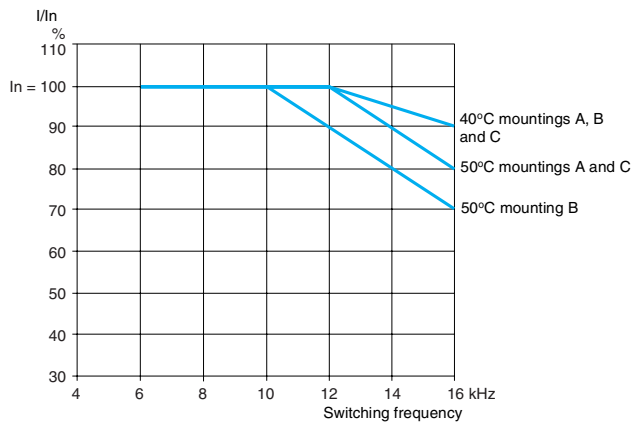

Mounting recommendations (continued)

Derating curves

ATV 21HU30N4

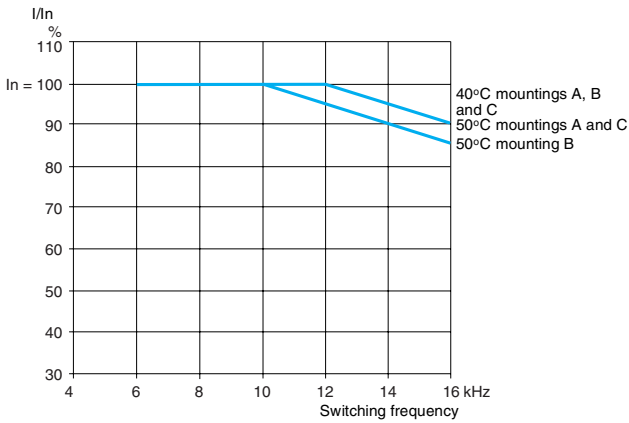

ATV 21HU40N4

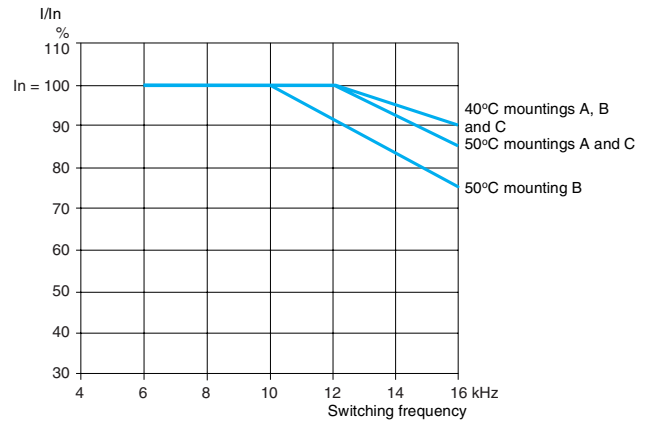

ATV 21HU55N4

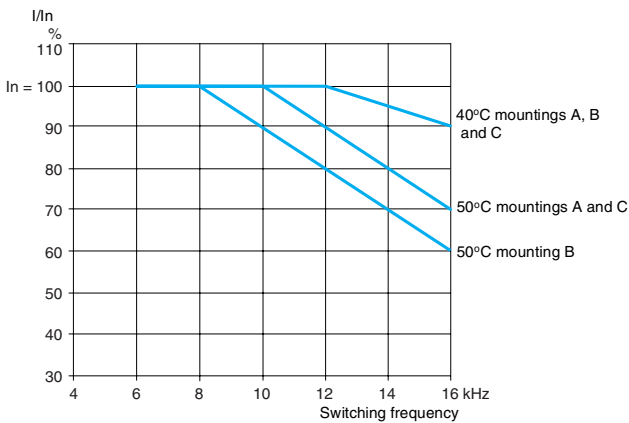

ATV 21HU75N4

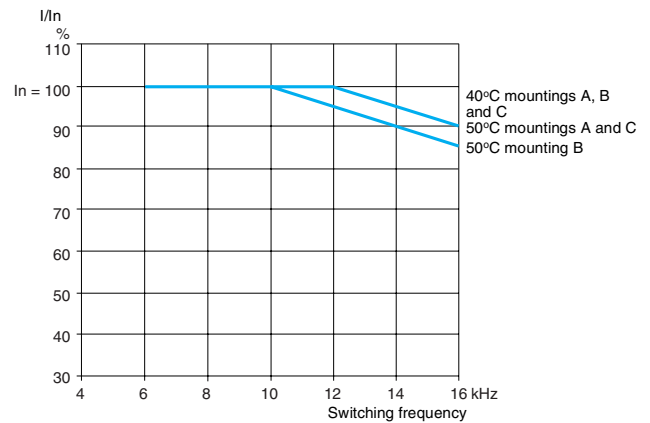

ATV 21HD11N4

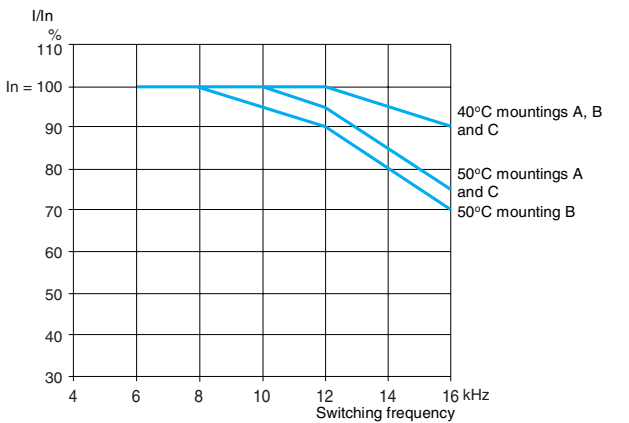

ATV 21HD15N4

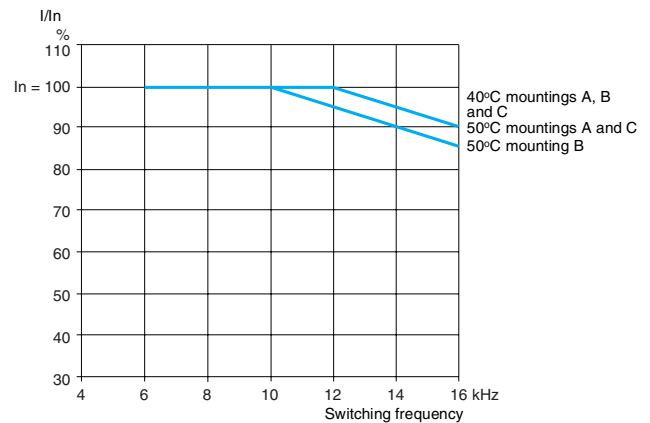

2

2.2

Mounting recommendations (continued)

Derating curves

ATV 21HD18N4

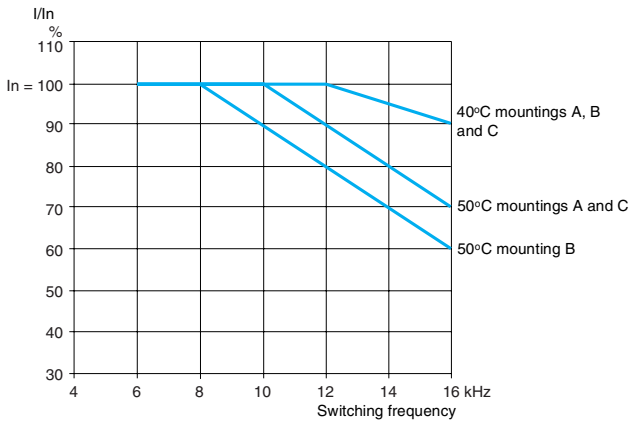

ATV 21HD22N4

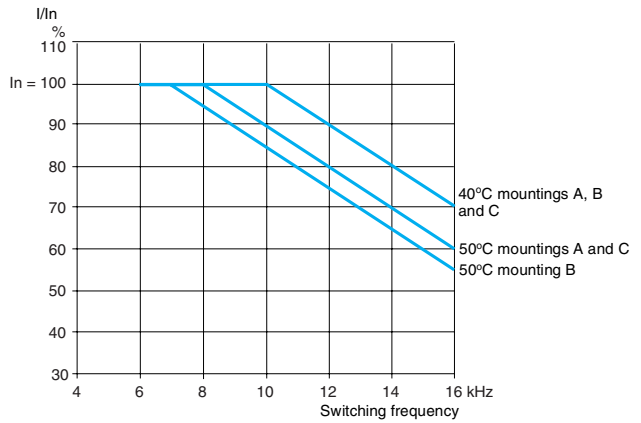

ATV 21HD30N4

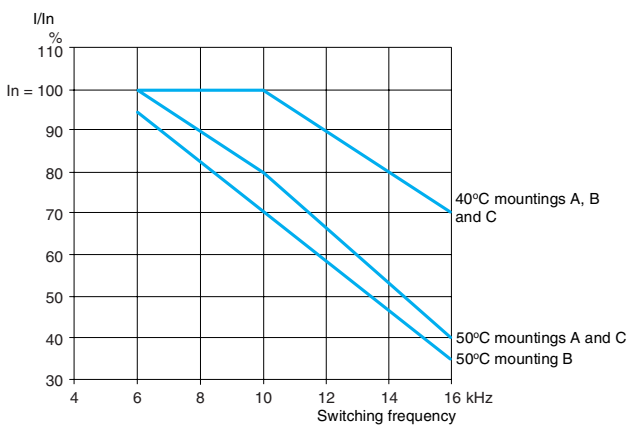

ATV 21HD37N4

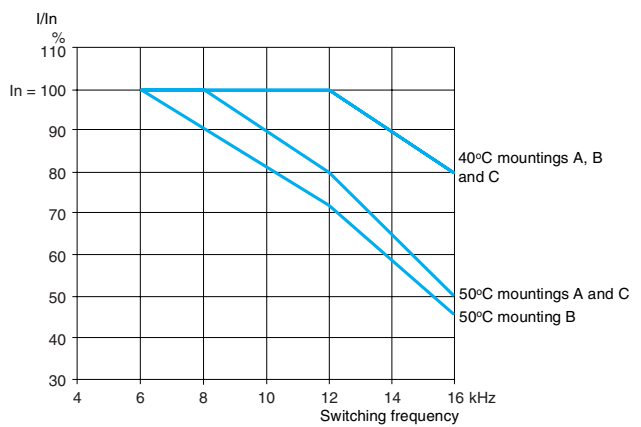

Mounting recommendations (continued)

Derating curves

ATV 21HD45N4

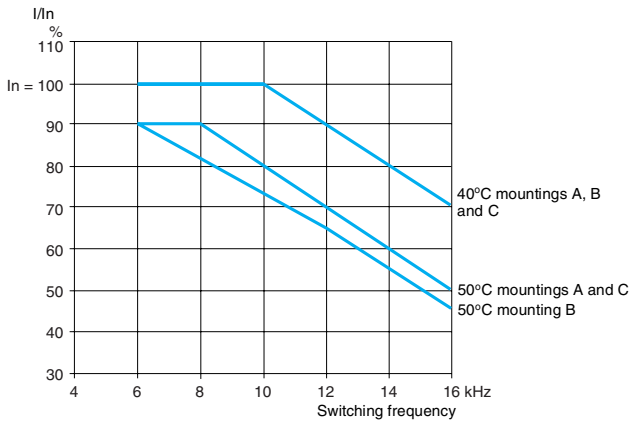

ATV 21HD55N4

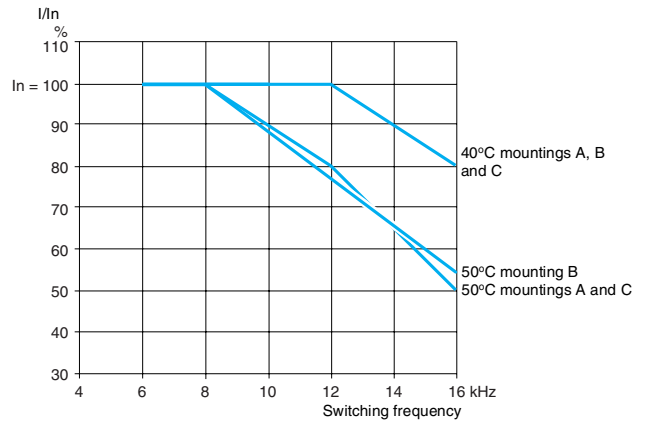

ATV 21HD75N4

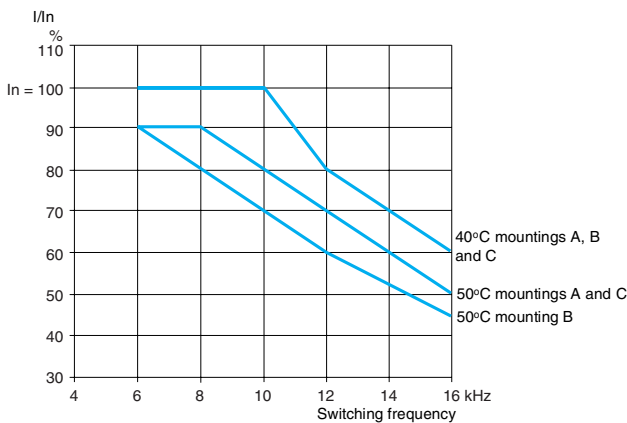

Mounting recommendations (continued)

Depending on the conditions in which the drive is to be used, its installation will require certain precautions and the use of appropriate accessories.

Install the unit vertically:

- Do not place it close to heating elements.
- Leave sufficient free space to ensure that the air required for cooling purposes can circulate from the bottom to the top of the unit.

ATV 21W000N4, ATV 21W000N4C

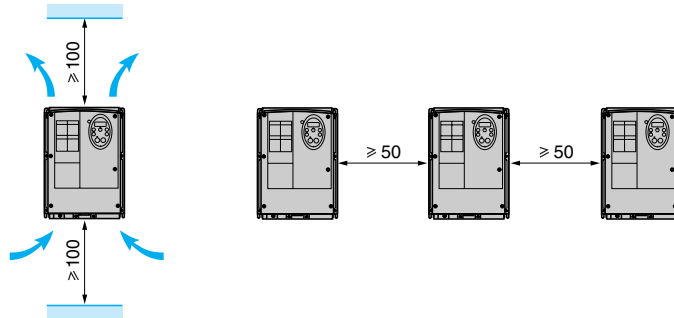

Derating curves

ATV 21W075N4...WU75N4, ATV 21W075N4C...WU75N4C

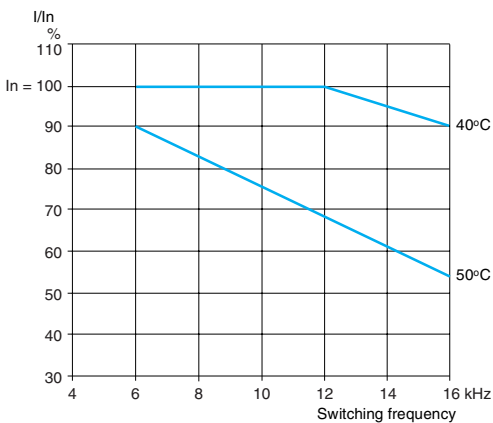

ATV 21WD11N4, ATV 21WD11N4C

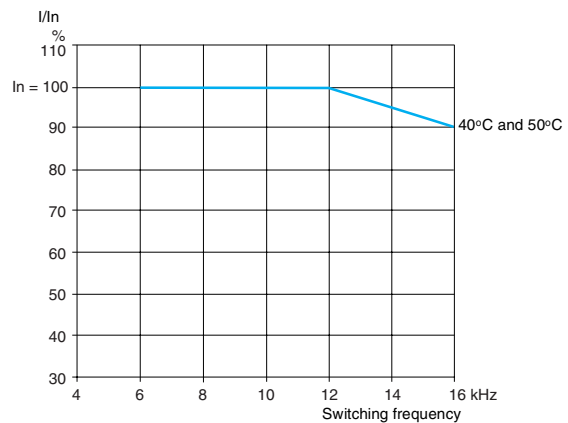

ATV 21WD15N4, ATV 21WD15N4C

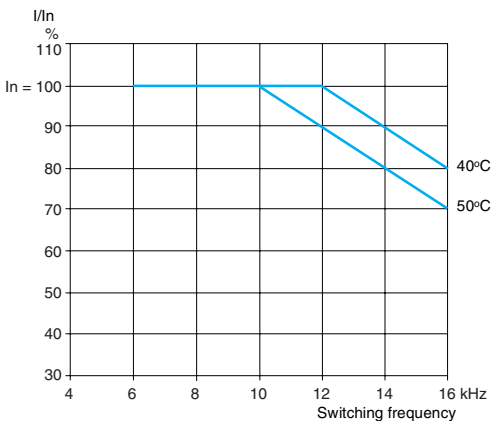

ATV 21WD18N4, ATV 21WD18N4C

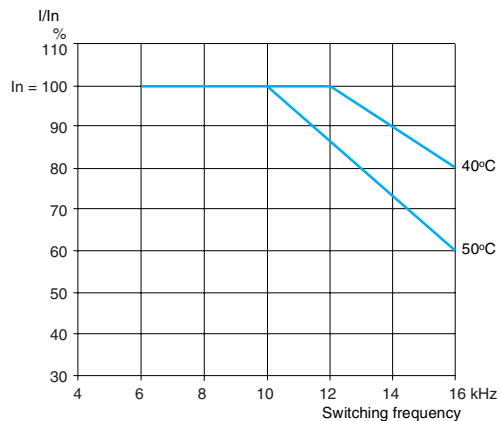

Mounting recommendations (continued)

Derating curves

ATV 21WD22N4, ATV 21WD22N4C

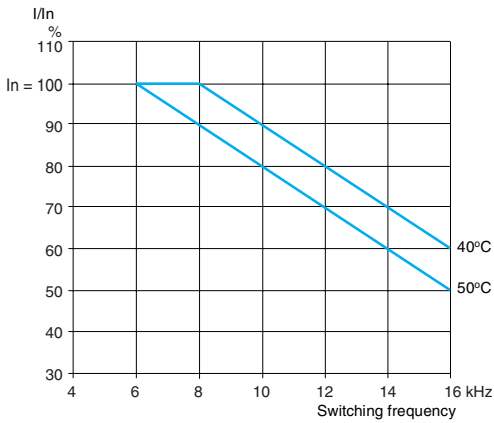

ATV 21WD30N4, ATV 21WD30N4C

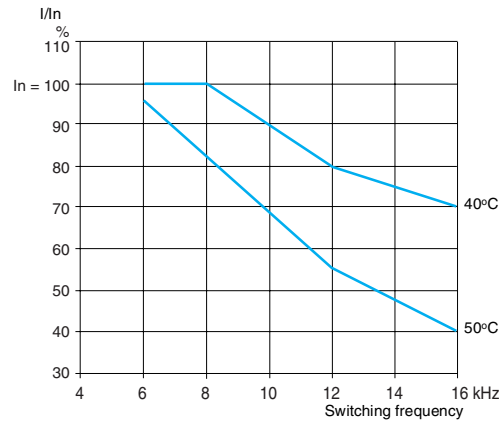

ATV 21WD37N4, ATV 21WD37N4C

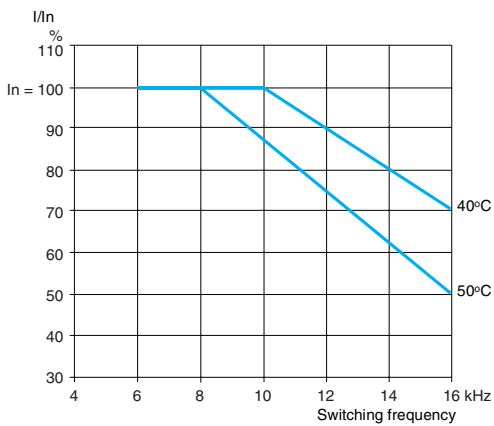

ATV 21WD45N4, ATV 21WD45N4C

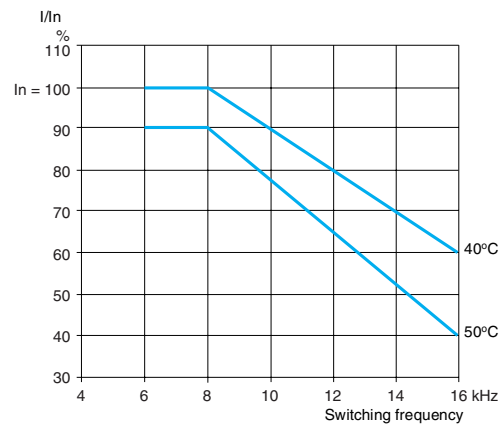

ATV 21WD55N4, ATV 21WD55N4C

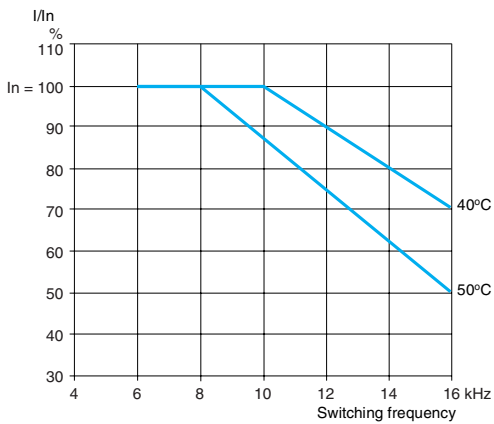

ATV 21WD75N4, ATV 21WD75N4C

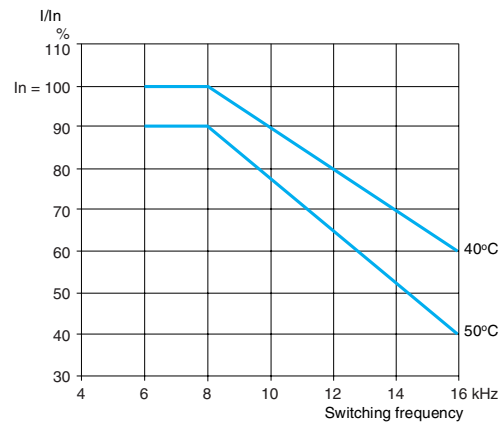

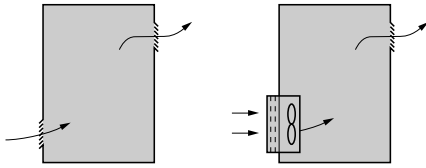

Specific recommendations for mounting in an enclosure (1)

Observe the mounting recommendations described on pages 2/70 to 2/75.

To ensure proper air circulation in the drive:

- Fit ventilation grilles.
- Ensure that there is sufficient ventilation. If there is not, install a forced ventilation unit with a filter. The openings and/or fans must provide a flow rate at least equal to that of the drive fans (see page 2/79).
- Use special filters with IP 54 protection.
- Remove the blanking cover from the top of the drive, see page 2/70.

Power dissipated inside the enclosure (1)

For drives	Dissipated power (2) W
Three-phase supply voltage: 200...240 V 50/60 Hz	
ATV 21H075M3X	63
ATV 21HU15M3X	101
ATV 21HU22M3X	120
ATV 21HU30M3X	146
ATV 21HU40M3X	193
ATV 21HU55M3X	249
ATV 21HU75M3X	346
ATV 21HD11M3X	459
ATV 21HD15M3X	629
ATV 21HD18M3X	698
ATV 21HD22M3X	763
ATV 21HD30M3X	1085

Three-phase supply voltage: 380...480 V 50/60 Hz

ATV 21H075N4	55
ATV 21HU15N4	78
ATV 21HU22N4	103
ATV 21HU30N4	137
ATV 21HU40N4	176
ATV 21HU55N4	215
ATV 21HU75N4	291
ATV 21HD11N4	430
ATV 21HD15N4	625
ATV 21HD18N4	603
ATV 21HD22N4	626
ATV 21HD30N4	847
ATV 21HD37N4	976
ATV 21HD45N4	1253
ATV 21HD55N4	1455
ATV 21HD75N4	1945

(1) For ATV 21H●●●M3X and ATV 21H●●●N4 drives only.

(2) This value is given for operation at nominal load and for a switching frequency of 8 or 12 kHz depending on the rating.

Fan flow rate depending on the drive rating

For drives	Flow rate m ³ /hour
ATV 21H075M3X	22
ATV 21HU15M3X	35
ATV 21HU22M3X	41
ATV 21HU30M3X	50
ATV 21HU40M3X	66
ATV 21HU55M3X	85
ATV 21HU75M3X	118
ATV 21HD11M3X	157
ATV 21HD15M3X	215
ATV 21HD18M3X	239
ATV 21HD22M3X	261
ATV 21HD30M3X	371
ATV 21H075N4	19
ATV 21HU15N4	27
ATV 21HU22N4	35
ATV 21HU30N4	47
ATV 21HU40N4	60
ATV 21HU55N4	74
ATV 21HU75N4	100
ATV 21HD11N4	147
ATV 21HD15N4	214
ATV 21HD18N4	206
ATV 21HD22N4	214
ATV 21HD30N4	290
ATV 21HD37N4	334
ATV 21HD45N4	429
ATV 21HD55N4	498
ATV 21HD75N4	666

Sealed metal enclosure (IP 54 degree of protection)

The drive must be mounted in a dust and damp proof enclosure in certain environmental conditions, such as dust, corrosive gases, high humidity with risk of condensation and dripping water, splashing liquid, etc.

This enables the drive to be used in an enclosure where the maximum internal temperature reaches 50°C.

Calculating the enclosure dimensions (1)

Maximum thermal resistance R_{th} (°C/W)

$$R_{th} = \frac{\theta - \theta_e}{P}$$

θ = maximum temperature inside enclosure in °C
 θ_e = maximum external temperature in °C
 P = total power dissipated in the enclosure in W

Power dissipated by drive: see page 2/78.

Add the power dissipated by the other equipment components.

Useful heat dissipation surface of enclosure S (m²)

(sides + top + front panel if wall-mounted)

$$S = \frac{K}{R_{th}}$$

K = enclosure thermal resistance per m²

For a metal enclosure:

- K = 0.12 with internal fan
- K = 0.15 without fan

Note: Do not use insulated enclosures, as they have a poor level of conductivity.

(1) For ATV 21H●●●M3X and ATV 21H●●●N4 drives only.

Summary of functions

Integrated 7-segment display terminal

Presentation page 2/82

Remote display terminal

Presentation page 2/82

Simplified start-up

Fan and centrifugal pump page 2/83

Quick Menu page 2/83

Operating modes

Default display mode page 2/84

Parameter adjustment mode page 2/84

Status monitoring mode page 2/84

Programming

Presentation page 2/85

Maintenance, diagnostics

Response to faults or alarms page 2/86

Fault log page 2/86

Identification of the software version page 2/86

Test functions page 2/86

Display of the I/O states page 2/86

Display of equipment maintenance alarms page 2/86

Controlling the drive via its I/O

Presentation page 2/87

Functions designed specifically for pumping and ventilation applications

Motor control profiles

- Energy saving ratio page 2/87

- Quadratic ratio (Kn²) page 2/87

PID regulator

- Preset PID references page 2/87

- PID feedback page 2/88

- PID feedback supervision page 2/88

- Sleep/Wake-up page 2/88

- Alarms page 2/88

- Auto/Man. page 2/88

Forced operation page 2/88

Other application functions

2-wire control page 2/89

3-wire control page 2/89

Acceleration and deceleration ramps

- Time page 2/89

- Automatic adaptation page 2/89

- Switching page 2/90

Preset speeds page 2/90

Limiting low speed operating time page 2/91

Variable speed drives for asynchronous motors

Altivar 21

Summary of functions (continued)

Other application functions (continued)

Motor control types		
- Sensorless flux vector control		page 2/91
- 2-point vector control		page 2/91
- Voltage/frequency ratio		page 2/91
- Synchronous motor		page 2/91
Auto-tuning		page 2/91
Switching frequency, noise reduction		page 2/91
+/- speed		
- Presentation		page 2/92
- Reference saving		page 2/92
Automatic catching of a spinning load with speed detection		page 2/92
Undervoltage management		page 2/93
Switching of 2 motor ratings		page 2/93
Current limit		page 2/94
Stop types		
- Freewheel stop		page 2/94
- Stop on ramp		page 2/94
- DC injection stop		page 2/94
Motor thermal protection		page 2/95
Drive thermal protection		page 2/96
IGBT thermal protection		page 2/96
Machine protection		page 2/96
Configuring the drive's fault response		page 2/96
Resetting resettable faults		page 2/97
General reset (disables all faults)		page 2/97
Automatic restart		page 2/97
PTC probe protection		page 2/98
IGBT testing		page 2/98
Resetting operating time to zero		page 2/98
External fault		page 2/98
Forced local mode		page 2/98

Variable speed drives for asynchronous motors

Altivar 21

2

2.2

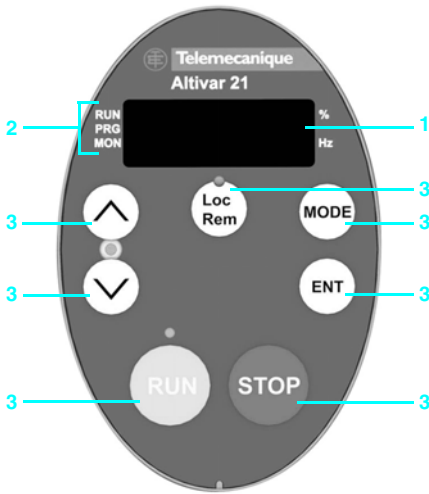

Integrated 7-segment display terminal

Integrated 7-segment display terminal

The Altivar 21 drive has an integrated 7-segment display terminal.

This can be used to:

- Display status and faults
- Access and modify parameters
- Check your installation easily in local mode using the Loc/Rem key **3**.

Description

1 Display:

- Four 7-segment displays visible at 5 m
- Display of numeric values and codes
- The display flashes when a value is stored
- Unit rating of displayed value
- The display flashes to indicate a fault on the drive

2 Display of drive status:

- RUN: Run command is active or speed reference present
- PRG: Drive in automatic mode
- MON: Drive in monitoring mode
- Loc: Drive in local mode

3 Use of keys:

- Loc/Rem: Switching of the drive command, locally or remotely. As a "local" command, the speed reference can be modified using the \wedge and \vee keys; the LED located between these keys lights up.
- \wedge and \vee : Vertical navigation in the menu, editing of values or speed reference depending on the mode selected
- MODE: Selection of one of the following modes:
 - Default display mode
 - Adjustment mode
 - Status monitoring mode
- RUN: Local motor run command; LED indicates that the RUN key is active
- STOP: Local control of motor stopping/drive fault clearing
- ENT: Saves the current value or the selected function

Remote display terminal

A remote display terminal is available as an option. It can be mounted on an enclosure door and allows access to the same functions as the integrated 7-segment terminal.

It is also possible to download and store 3 configuration files using its "COPY MODE" (see page 2/51).

Variable speed drives for asynchronous motors

Altivar 21

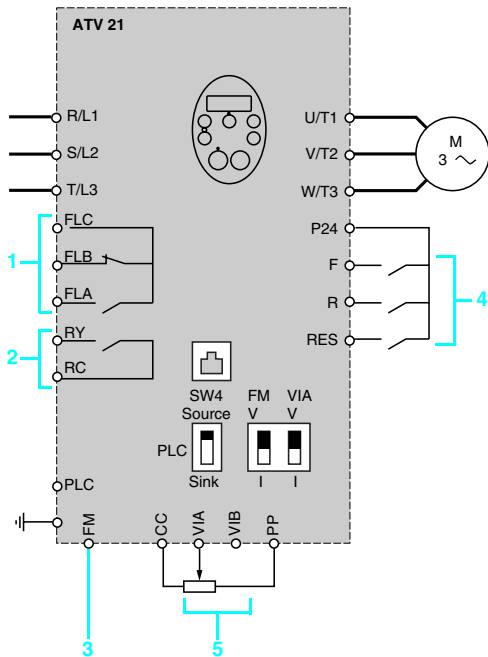

Factory-set configuration

Simplified start-up

Fan and centrifugal pump

The Altivar 21 drive is factory-configured to allow a simplified start-up, without the need for any adjustment.

The following conditions must be met to be able to use this simplified start-up function:

- The drive load must be a fan or a centrifugal pump
- The motor rating must match the drive rating
- Connection must be according to the diagram opposite:
 - 1 FLA, FLB and FLC for the fault relay
 - 2 RY and RC for the low speed reached relay
 - 3 FM for the analog output
 - 4 F, R and RES for the logic inputs:
 - F for forward operation
 - R for preset speed
 - RES for fault reset
 - 5 VIA and VIB for the analog inputs:
 - VIA for the speed reference 0...10 V
 - VIB is not assigned

Quick Menu

The Quick Menu is used to:

- Access the essential parameters of your application quickly
- Enter the motor rating plate data (nominal voltage, nominal frequency, thermal current, etc.), so that the motor parameters can be adjusted quickly, thereby benefiting from optimum motor performance
- Protect the motor by setting the drive's integrated electronic thermal overload relay

Parameters which can be accessed in the Quick Menu (AUF):

Parameter	Description
AU1	Automatic acceleration/deceleration
ACC	Acceleration
dEC	Deceleration
LL	Low speed
UL	High speed
tHr	Motor thermal current
FM	Analog output
Pt	U/F Profile
uL	Nominal motor frequency
uLu	Nominal motor voltage

Variable speed drives for asynchronous motors

Altivar 21

2

2.2

Operating modes

The Altivar 21 drive has the following operating modes:

- Default display mode
- Parameter adjustment mode
- Status monitoring mode

It is easy to switch between these different modes simply by using the "MODE" key:

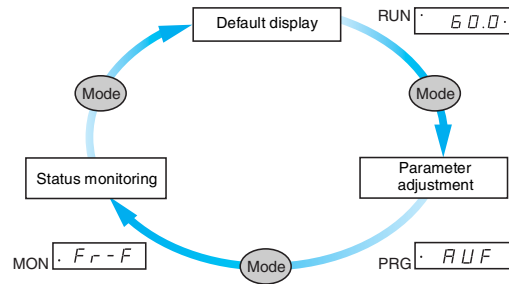

Default display mode

This mode is automatically activated on power-up. It is used to display a drive variable (current, speed, etc.), alarms and faults.

Parameter adjustment mode

This mode provides a simple start-up function for the drive via direct access to the standard parameters:

- Acceleration
- Deceleration
- Macro-configuration
- Control mode
- Motor rating plate
- Etc.

The standard parameters are identified by an alphanumerical code (ACC, dEC, etc.)

This mode also provides access to the advanced parameters required for setting up and optimizing advanced functions.

These parameters are identified by a numerical code (F100 to F900).

Status monitoring mode

This mode is used to display all the drive variables, such as the I/O state, most recent faults, etc.

Programming

The main menus accessible from the integrated 7 segments terminal are described in the table below:

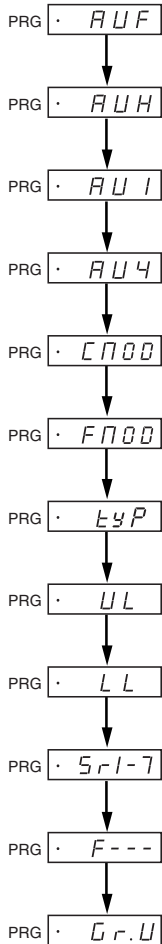

Main menus of the integrated 7-segment display terminal

Menu type	Function
AUF	Accessing the Quick Menu
AUH	Accessing the most recently modified parameters
AU1	Selecting the ramp type (fixed or automatically adapted)
AU4	Selecting the macro-configurations
CMOD	Selecting the command channel
FMOD	Selecting the reference channel
tyP	Selecting the factory settings or the customer configuration
UL	Setting high speed
LL	Setting low speed
Sr1-7	Accessing preset speeds
F---	Accessing advanced parameters
Gr.U	Accessing parameters that are different to the factory settings

Variable speed drives for asynchronous motors

Altivar 21

2

2.2

Maintenance, diagnostics

New functions have been added to the Altivar 21 drive to enable it to provide quick and simple maintenance, ultimately boosting productivity:

■ Response to faults or alarms

It is possible to use the alarm management or drive operation configuration functions to take corrective measures before stopping the machine.

■ Fault log

When a fault occurs, values such as speed, current, thermal state and timer are saved and restored in the fault log. The last 4 faults are stored.

■ Identification of the software version

It is possible to display the relevant serial numbers and software versions, thereby helping to manage the equipment base.

■ Test functions

The Altivar 21 drive includes the following test functions:

- Identifying any motor short-circuit before start-up
- Running, via the 7-segment display terminal, the remote display terminal or the PC software, automatic procedures during maintenance operations aimed at testing:
 - the motor
 - the drive power components

■ Display of the I/O states

It is possible to display the activation or deactivation state of each input/output.

- 1 VIA: State 1
- 2 RES: State 1
- 3 R: State 0
- 4 F: State 1

■ Displaying equipment maintenance alarms

Three alarms show if it is necessary to replace the drive or some of its components.

The drive automatically calculates their service lives by configuring their average annual operating temperature.

- 1 Drive: Alarm deactivated
- 2 Capacitor: Alarm deactivated
- 3 Fan: Alarm activated



Example of the I/O state display

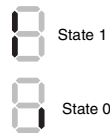

Example of alarms display

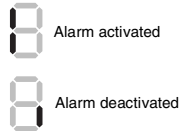

Variable speed drives for asynchronous motors

Altivar 21

2

2.2

Controlling the drive via its I/O

Control signals are transmitted via cable to the I/O. Functions are assigned to logic inputs, analog inputs, etc.

A logic input can be assigned to more than one function. This means that two functions can be controlled using a single signal, thereby limiting the number of inputs required.

The Altivar 21 drive I/O can be configured independently from each other. For instance:

- A time delay can be applied when it comes to reading the logic inputs, so as to avoid any bounce-back from certain switches.
- Transforming incoming signals on the analog inputs can help the drive fully adapt to the control devices and applications:
 - Minimum and maximum values for the input signal
 - Input filtering in order to eliminate unwanted interference from the signals received
 - Magnifying glass effect through delinearizing the input signal in order to increase the precision with small amplitude signals
 - "Pedestal" and "Deadband" functions for signals in order to prevent low speed operations which can have an adverse effect on the application
- Transforming analog outputs which transfer information sent by the drive to other devices (display units, drives, PLCs, etc.):
 - voltage or current output signal
 - minimum and maximum values for the output signal
 - output signal filtering

Logic outputs can be delayed on activation and deactivation. The output state can also be configured when the signal is active.

Functions designed specifically for pumping and ventilation applications

■ Motor control profiles

□ Energy saving ratio

This type of command makes it possible to optimize the energy consumed based on the load applied to the machine.

□ Quadratic ratio (Kn²)

This type of command is optimized for centrifugal pumps and fans.

■ PID regulator

This can be used to regulate a process with a reference and feedback given by a sensor.

Function suitable for regulation in buildings.

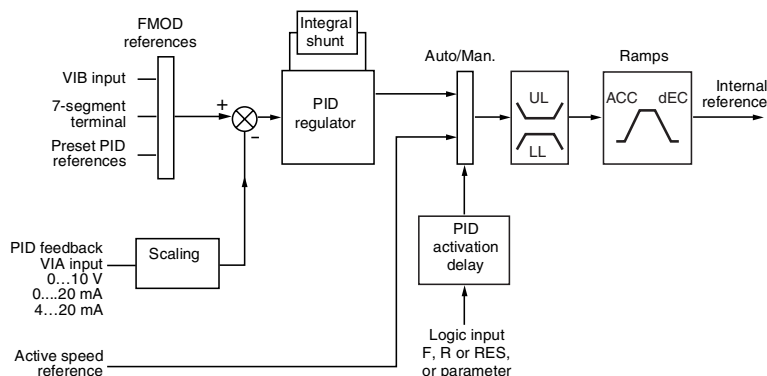

ACC: Acceleration, dEC: Deceleration, LL: Low speed, UL: High speed.

□ Preset PID references

2 to 7 PID references are available.

Variable speed drives for asynchronous motors

Altivar 21

Other application functions

■ 2-wire control

This function is used to control the direction of operation by means of a stay-put contact.

It is enabled by means of 1 or 2 logic inputs (non-reversing and preset speed).

This function is suitable for all non-reversing applications, by detection of the logic input state.

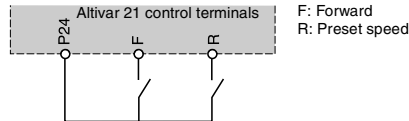

Wiring diagram for 2-wire control

■ 3-wire control

This function is used to control the operating and stopping direction by means of pulsed contacts. It is enabled by means of 2 or 3 logic inputs.

This function is suitable for all non-reversing applications and stopping.

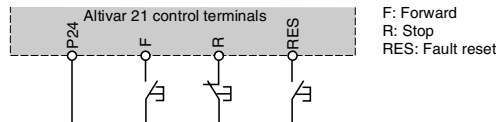

Wiring diagram for 3-wire control

■ Ramps

□ Acceleration and deceleration ramp times

This function is used to define acceleration and deceleration ramp times according to the application and the machine dynamics.

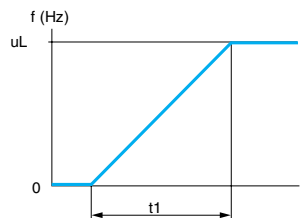

Linear acceleration ramp

uL: Nominal motor frequency

t1: Acceleration time

t2: Deceleration time

t1 and t2 can be set independently from 0.01 to 3200 s (according to one of the following ramp increments:

0.01 s, 0.1 s or 1 s);

Factory setting: 10 s.

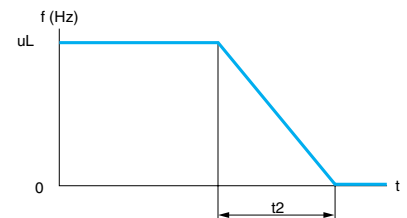

Linear deceleration ramp

□ Automatic adaptation of acceleration and deceleration ramps

This function can be used to adapt the acceleration and deceleration ramps automatically based on the load.

The acceleration and deceleration times are reduced for low loads and increased for high loads.

Low load

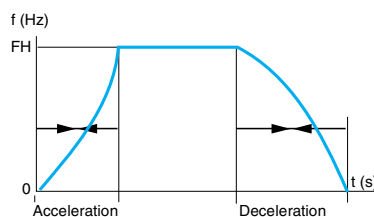

FH: Maximum output frequency

High load

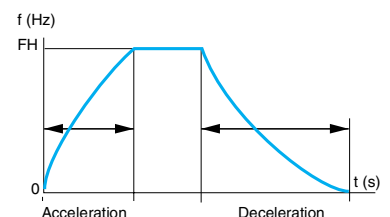

FH: Maximum output frequency

Variable speed drives for asynchronous motors

Altivar 21

2

2.2

■ Ramps (continued)

□ Ramp switching

This function is used to switch two acceleration and deceleration ramp times, which can be adjusted separately.

Ramp switching can be enabled by:

- a logic input
- a frequency threshold
- a command word bit

This function is suitable for all machines with fast steady state speed correction.

■ Preset speeds

This can be used to switch preset speed references.

Choice of seven preset speeds.

Enabled by logic inputs, R and RES, and by VIA configured as a logic input.

The preset speeds are adjustable in increments of 0.1 Hz, from low speed to high speed.

This function is suitable for machines with several operating speeds.

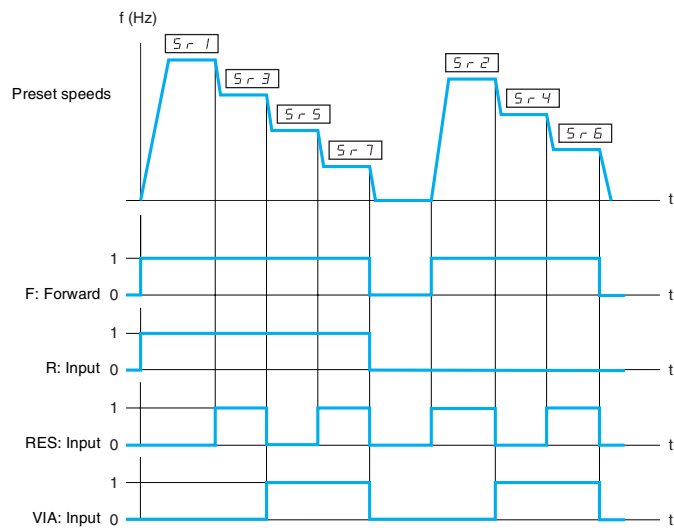
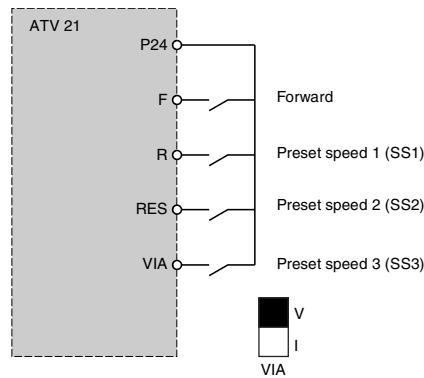

Example of operation with 7 preset speeds

Variable speed drives for asynchronous motors

Altivar 21

■ Limiting low speed operating time

The motor is stopped automatically after a period of operation at low speed (LL) with a zero reference and a run command present.

This time can be set between 0.1 and 600 seconds (0 corresponds to an unlimited time). Factory setting 0 s. The motor restarts automatically on the ramp when the reference reappears or if the run command is interrupted and then re-established.

Function suitable for automatic Stops/Starts.

■ Motor control types

□ Sensorless flux vector control

This control type can be used with a single motor or motors connected in parallel.

□ 2-point vector control

The zone for operating at constant power can be optimized by defining an additional point in the control profile.

This function should be used with motors offering a two-part defluxing zone.

It can be used to limit the voltage at the motor terminals when the motor is being powered by a high line supply.

□ Voltage/frequency ratio

This control type is particularly suitable for special motors (high-speed motors, synchronized asynchronous motors, etc.). The ratio can be adjusted by 2 points and used to achieve output frequencies of up to 200 Hz.

□ Synchronous motor

This control type is exclusively reserved for controlling open loop synchronous permanent magnet motors with sinusoidal electromotive force (EMF).

■ Auto-tuning

Auto-tuning can be performed:

- Using a dialogue tool (integrated 7-segment display terminal, remote display terminal or PC software)
- Via a communication network

■ Switching frequency, noise reduction

The switching frequency setting permits a reduction in the noise generated by the motor for any application requiring a low level of noise.

The switching frequency is modulated randomly in order to avoid resonance. This function can be disabled if it causes instability.

Switching the intermediate DC voltage at high frequency is useful for supplying the motor with a current wave having little harmonic distortion.

The switching frequency is adjustable during operation to reduce the noise generated by the motor.

Value: 6 to 16 kHz

Variable speed drives for asynchronous motors Altivar 21

2

2.2

■ +/- speed

Used to increase or decrease a speed reference by means of 1 or 2 logic inputs, with or without the last reference being saved (motorized potentiometer function). This function is suitable for centralized control of a machine with several sections operating in one direction.

Two logic inputs are required in addition to the operating direction for +/- speed control.

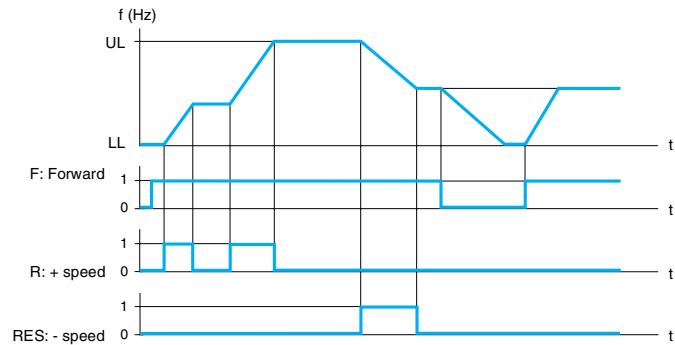

LL: Low speed, UL: High speed

□ Reference saving

This function is associated with +/- speed control.

This can be used for reading and saving the last speed reference prior to the loss of the run command or line supply. The saved reference is applied at the next run command.

■ Automatic catching of a spinning load with speed detection ("catch on the fly")

This function is used to restart the motor smoothly after one of the following events, provided the run command is still present:

- loss of line supply or power off
- fault reset or automatic restart
- freewheel stop

On disappearance of the event, the effective speed of the motor is detected in order to restart on a ramp at this speed and return to the speed reference. The speed detection time can reach 0.5 s.

This function is suitable for machines which exhibit low motor speed loss during a power failure (high-inertia machines such as centrifuges, etc.).

Variable speed drives for asynchronous motors

Altivar 21

■ Undervoltage management

Depending on the application, it is possible to configure the Altivar 21's response to undervoltages or power failures.

If the drive locks as a result, management of the fault relay can be configured (open or not). If the fault relay does not open an alarm is shown.

The Altivar 21 drive can also be configured to prevent the drive locking (using an alarm):

- Controlled stop according to the type of stop configured
- Deceleration based on a ramp which it automatically adapts to maintain the DC bus voltage, thereby preventing the drive from locking in fault mode
- Instant IGBT (inverter bridge) loss followed by power supplied to the motor as soon as the line voltage has reappeared. This function can be used to prevent the Altivar 21 drive being reinitialized.

■ Switching of 2 motor ratings

This function is used to switch two sets of 10 motor parameters:

- All or some of the motor parameters can be switched on stopping
 - Some of these parameters can be switched during operation
- A logic input or command word bit is used to switch the sets.

Command and reference switching via logic input

This function is used to switch commands (terminal, logic inputs) and references (speed, PID, etc.) via a logic input.

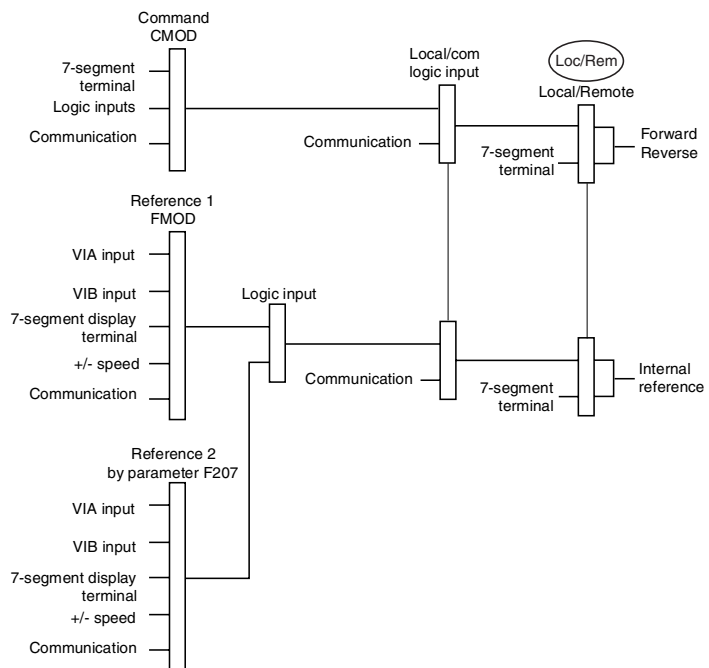

Example of command and reference switching

2

2.2

Variable speed drives for asynchronous motors

Altivar 21

2

2.2

■ Current limit

A second current limit can be configured up to 1.1 times the drive nominal current and it can be used to limit the rise in motor temperature and the torque.

Switching between the two current limits can be enabled via:

- a logic input
- a command word bit

■ Stop types

Freewheel stop

This function stops the motor by resistive torque if the motor power supply is cut.

A freewheel stop is achieved:

- by configuring a normal stop command as a freewheel stop (on disappearance of a run command or appearance of a stop command)
- by enabling a logic input
- by activating a command word bit

Stop on ramp

This stops the motor according to the deceleration ramp

A stop on ramp is achieved:

- by enabling a logic input
- by activating a command word bit

DC injection stop

This can be used to brake high-inertia machines at low speed or maintain torque on stopping.

A DC injection stop is achieved:

- by configuring a normal stop as a DC injection stop (on disappearance of a run command or appearance of a stop command)
- by enabling a logic input
- by activating a command word bit

The DC value and the standstill braking time are adjustable.

Variable speed drives for asynchronous motors

Altivar 21

■ Motor thermal protection

Motor thermal protection is provided by the drive:

- directly, through PTC probes located in the motor windings
- indirectly, via the integrated thermal relay. Indirect thermal protection is implemented via continuous calculation of its theoretical temperature rise.

The microprocessor calculates the theoretical temperature rise of the motor based on various elements:

- the operating frequency
- the current taken by the motor
- the operating time
- the maximum ambient temperature around the motor (40°C)
- the type of motor ventilation (self-cooled or force-cooled)

Thermal protection is adjustable from 0.5 to 1.1 times the nominal current, depending on the drive type. It must be adjusted to the nominal current indicated on the motor rating plate.

Note: The motor thermal state memory returns to zero when the drive control part is switched off.

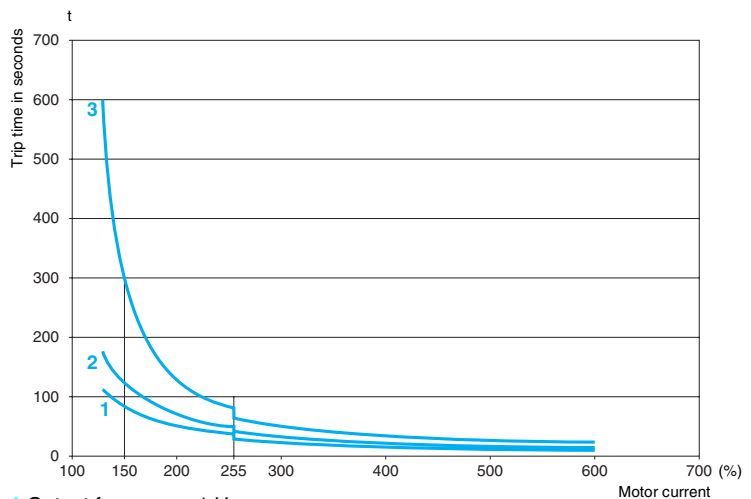

- 1 Output frequency: 1 Hz
- 2 Output frequency: 10 Hz
- 3 Output frequency: 30 Hz and above

Motor thermal protection curves

- Self-cooled motors:
The tripping curves vary with the motor frequency.
- Force-cooled motors:
Only the 30 Hz and higher tripping curve should be considered, whatever the motor frequency.

Variable speed drives for asynchronous motors

Altivar 21

■ Drive thermal protection

The drive thermal protection is provided by a PTC probe mounted on the heatsink or integrated with the power module.

■ IGBT thermal protection

The drive manages the switching frequency intelligently according to the IGBT temperature.

If the drive's current rating is exceeded (e.g.: current higher than the nominal drive current for a zero stator frequency), an alarm is displayed and a timer increases for as long the alarm is present.

■ Machine protection

This is used to detect under- and/or overload.

■ Configuring the drive's fault response (fault management)

Different responses can be configured for the drive in the event of a resettable fault occurring:

- freewheel stop
- drive switches to the fallback speed
- drive maintains the speed at which it was operating when the fault occurred until the fault disappears
- stop on ramp
- DC injection stop
- no stop (alarm activated)

List of resettable faults:

- external fault
- output phase loss
- auto-tuning fault
- loss of 4-20mA
- PTC probe
- drive overheating
- motor overload if the thermal state is less than 100%
- line overvoltage
- current limit
- IGBT overheating
- communication faults (Modbus and other communication networks)
- PI supervision

Variable speed drives for asynchronous motors

Altivar 21

■ Resetting resettable faults

This can be used to remove the last fault using a logic input, command word bit or the STOP/RESET key on the display terminal.

The restart conditions after a reset to zero are the same as those of a normal power-up.

List of resettable faults, see “Configuring the drive’s fault response”.

Line supply undervoltage and input phase loss faults are reset automatically when the line supply is restored.

Function suitable for applications where drives are difficult to access, such as when a drive is placed on a moving part.

■ General reset (inhibits all faults)

This function inhibits all faults, including thermal protection (forced operation), which can destroy the drive.

This function is suitable for applications where restarting is vital (smoke extraction system, machines with hardening products that need to be removed).

The function is enabled by a logic input.

Fault monitoring is active if the logic input is at state 1.

All faults are reset on a change of state \uparrow of the logic input.

Note: Use of this function invalidates the guarantee.

■ Automatic restart

This function enables the drive to be restarted automatically after it has locked in fault mode, provided the relevant fault has disappeared and that the other operating conditions permit a restart.

This restart is performed by a series of automatic attempts separated by increasingly longer waiting periods of 1, 2, 3 s, then 10 s, up to the 10th attempt.

If the drive has not restarted after the configured time, it will lock and the procedure is abandoned until it has been powered off and on again.

The faults which permit this type of restart are:

- line overvoltage
- motor thermal overload
- drive thermal overload
- DC bus overvoltage
- line phase failure
- external fault
- loss of 4-20mA
- PTC probe
- serial link
- current limit
- output phase loss
- line voltage too low. For this fault, the function is always active, even if it is not configured.
- PI supervision,
- fault caused by Modbus or other communication networks. These faults are reset automatically as soon as the command word or frequency reference is sent to the drive.

For these types of fault, the relay configured as a fault relay remains activated if the function is configured. The speed reference and direction of operation must be maintained for this function.

This function is suitable for machines or installations which are in continuous operation or are not monitored, and where a restart will not endanger equipment or personnel in any way.

Variable speed drives for asynchronous motors

Altivar 21

■ PTC probe protection

The probes can be connected directly to the drive control card or to the communication cards.

The way in which a temperature fault is recorded by the drive can be configured by default or as an alarm.

■ IGBT testing

When enabled, this function tests every IGBT and the motor connections in order to detect a short-circuit or an open circuit. This test is run every time the drive is powered on and before each motor start.

■ Resetting operating time to zero

The drive operating and power-up time can be reset.

■ External fault

This function can lead to the drive locking if a fault occurs in the machine. This fault is flagged on the drive display unit. The fault is flagged if the signal is at 1 or at 0, according to the function configuration.

■ Forced local mode

Forced local mode imposes control via the logic input and prohibits all other control modes.

Switching to forced local mode may be activated via:

- a logic input
- a function key on the display terminal

The following references and commands are available for forced local mode:

- references VIA, VIB, and command via logic inputs
- reference and command via the display terminal

Function compatibility table

■ **Configurable I/O**

The table below lists the incompatibilities between the functions and shows the priority functions.

Stop functions have priority over run commands.

The selection of functions is limited:

- by the number of drive I/O which can be reassigned
- by the incompatibility of certain functions with one another

Functions	PID regulator	Preset speeds	+/- speed	Freewheel stop	DC injection stop	Forced operation
PID regulator			⊖			→
Preset speeds			⊖			→
+/- speed	⊖	⊖				⊖
Freewheel stop					←	→
DC injection stop				↑		⊖
Forced operation	↓	↓	⊖	↓	⊖	

-  Incompatible functions
-  Compatible functions
-  Not applicable

Priority functions (functions which cannot be active at the same time)

-  The arrow indicates which function has priority.
For example, the Freewheel stop function has priority over the DC injection stop function.